

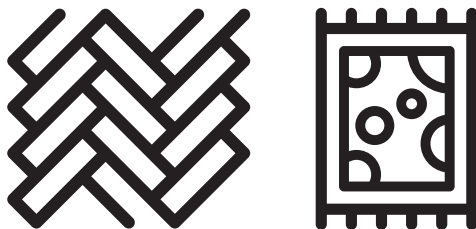

## Robot Vacuum Cleaner

User Manual



VRR 60314 VW

EN



01M-8914023200-4622-01

## Please read this guide first!

Dear Customer,

Thank you for choosing a Beko product. We would like you to achieve the optimal efficiency from this high quality product which has been manufactured with the state of the art technology. Please make sure you read and understand this guide and supplementary documentation fully before use and keep it as a reference. Include this guide with the unit if you hand it over to someone else. Observe all warnings and information herein and follow the instructions.

## Symbols and their meanings

Following symbols have been used throughout this guide:



Important information and beneficial advices regarding the usage of the device.



**WARNING:** Warnings about dangerous situations regarding safety of life and property.



Protection class against electric shock.

# CONTENTS

---

## **1 Important safety and environmental instructions 4**

---

- 1.1 General safety . . . . . 4
- 1.2 Compliance with the WEEE regulations and waste disposal . . . . . 9
- 1.3 Packaging information . . . . . 9
- 1.4 Waste batteries. . . . . 9
- 1.5 CE Declaration of Conformity . . . . . 9
- 1.6 What to do for energy saving . . . . . 9
- 1.7 Plug Wiring. . . . . 10

## **2 Box content 11**

---

## **3 Overview 12**

---

- 3.1 Checks and components . . . . . 13
- 3.2 Technical data. . . . . 13

## **4 Installation 15**

---

## **5 Operation 17**

---

- 5.1 Intended use. . . . . 17
- 5.2 Operation . . . . . 17
  - 5.2.1 Operation with the application. . . . . 20
- 5.3 Operation of the mop . . . . . 22
  - 5.3.1 Installation of the wet mopping unit. . . . . 2
  - 5.3.2 Wet mopping setting . . . . . 24

## **6 Cleaning and maintenance 24**

---

- 6.1 Cleaning the dust container and filters . . 24
- 6.2 Cleaning of the brush . . . . . 26
- 6.3 Cleaning and installation of the side brush 27
- 6.4 Cleaning of the Sensors & Front wheel . . 27
- 6.5 Cleaning of the mopping unit. . . . . 29

## **7 Troubleshooting 30**

---

# 1 Important safety and environmental instructions

This section contains safety instructions to prevent hazards that can result in injury or property damage.

Any warranty is void if these instructions are not followed.

## 1.1 General safety

- This appliance complies with international safety standards.
- This appliance can be used by children 8-years-old over 8 years of age, people with physical, sensory or mental challenges or people with lack of experience or knowledge; as long as control is ensured or information is provided regarding safe usage of the device and the hazards involved. Children must not play with the appliance. Cleaning and user maintenance should not be carried out by unattended children.
- Do not use the appliance if the power cord or the appliance is damaged. Contact authorised service.
- Keep the appliance and its cable out of the reach of children under 8 years of age.
- Do not power your device with multi socket.
- Your mains power supply should be in align with the specified information on the type tag of the appliance.
- Do not use the appliance with an extension cord.

## 1 Important safety and environmental instructions

- To prevent damage to the power cord, prevent it from being pinched, crimped or rubbed against sharp edges.
- Do not touch the plug of the appliance with damp or wet hands while the appliance is plugged in.
- Do not pull on the cord while unplugging the appliance.
- Do not vacuum flammable materials and ensure that the cigarette ashes are cooled down before vacuuming them.
- Do not vacuum water and other fluids.
- Protect the appliance against precipitation, humidity and heat sources.
- Do not use the appliance in or near explosive or flammable environments and substances.
- Unplug the appliance before cleaning and maintenance.
- This product is not designed for commercial use, it is intended for use at home and in applications as follows:
  - In the staff kitchens of the stores, offices and other working environments,
  - In farm houses,
  - By customers in hotels, motels or other accommodation facilities;
  - In hostels, or similar environments.
  - Sleeping places and breakfast environments

## 1 Important safety and environmental instructions

- Do not immerse the appliance or its power cord in water for cleaning.
- Do not disassemble the appliance.
- Use only original parts or parts recommended by the manufacturer.
- To prevent blockage of the filter or damage to the motor, do not vacuum cement, plaster or fragments of compressed paper.
- Use the appliance with the adapter delivered with the appliance only.
- Do not use the appliance without filters, it may get damaged.
- If you keep the packaging materials, keep them out of the reach of children.
- This appliance is not intended to be used by persons, including children, with physical, sensory and mental disabilities or those who have not adequate experience and knowledge regarding its use, unless they are under the supervision of a person responsible for their safety or they are informed about the operation of the appliance.
- The children shall be supervised to prevent them from playing with the appliance.
- Unplug the adapter and remove the battery pack before any cleaning or maintenance procedure.

## 1 Important safety and environmental instructions

- To avoid any risk of hazard, a damaged adapter shall be replaced by the manufacturer, the authorised representative of the manufacturer or a similarly qualified technician.
- Keep your fingers, hair and loose clothes away from moving parts or clearances while vacuuming.
- Please discard used batteries in accordance with local laws and regulations.
- The batteries in this appliance may only be replaced by the authorised service.
- Do not use batteries of different types or old and new batteries together.
- Do not short circuit the supply terminals.
- Shall be used with ME1XXFG CM 2600 mAh batteries only.
- This appliance shall not be operated by children and people with limited physical, sensory and cognitive skills or people with lack of experience and knowledge unless they are under supervision or they are provided with the relevant instructions.
- The children shall be supervised to prevent them from playing with the appliance.
- Do not put weight on the appliance. Make sure that the children and domestic animals do not get on the appliance.

## 1 Important safety and environmental instructions

- Do not run the appliance on high grounds like table or chair.
- The appliance is only to be used with the unit provided.
- The appliance is not to be used by persons (including children) with reduced physical, sensory or mental capabilities, or lack of experience and knowledge, unless they have been given supervision or instruction.
- This appliance can be used by children aged from 8 years and above and persons with reduced physical, sensory or mental capabilities or lack of experience and knowledge if they have been given supervision or instruction concerning use of the appliance in a safe way and understand the hazards involved.
- Children being supervised not to play with the appliance.
- Cleaning and user maintenance shall not be made by children without supervision.
- This appliance contains batteries that are only replaceable by skilled persons.



# 1 Important safety and environmental instructions

## 1.2 Compliance with the WEEE regulations and waste disposal



This product complies with EU WEEE Directive (2012/19/EU).

This product bears a classification symbol for waste electrical and electronic equipment (WEEE).

This symbol indicates that this product shall not be disposed with other household wastes at the end of its service life. Used device must be returned to official collection point for recycling of electrical and electronic devices. To find these collection systems please contact to your local authorities or retailer where the product was purchased. Each household performs important role in recovering and recycling of old appliance. Appropriate disposal of used appliance helps prevent potential negative consequences for the environment and human health.

## 1.3 Packaging information



The product's packaging is made of recyclable materials, in accordance with the National Legislation.

Do not dispose of the packaging waste with the household waste or other wastes, dispose it to the packaging collection areas specified by local authorities.

## 1.4 Waste batteries



This symbol on rechargeable batteries/ batteries or on the packaging indicates that the rechargeable battery/battery may not be disposed of with regular house hold rubbish. For certain rechargeable batteries/batteries, this symbol may be supplemented by a chemical symbol. Symbols for mercury (Hg) or lead (Pb) are provided if the rechargeable batteries/batteries contain more than 0,0005 % mercury or more than 0,004 % lead.

Rechargeable batteries/batteries, including those which do not contain heavy metal, may not be disposed of with household waste. Always dispose of used batteries in accordance with local environmental regulations. Make enquiries about the applicable disposal regulations where you live.

## 1.5 CE Declaration of Conformity

As Arçelik A.Ş., we declare that this product and/or these products comply with the directive 2014/53/EU. The full text of the EU declaration of conformity is available at the following website: [beko.com.tr](http://beko.com.tr)

## 1.6 What to do for energy saving

- When using your appliance, adjust the speed settings according to the surface, in order to save energy.
- Normally, lower speeds are used when cleaning hard surfaces while high speeds are used for cleaning carpets.

# 1 Important safety and environmental instructions

## 1.7 Plug Wiring

The moulded plug on this appliance incorporates a 13 A fuse. Should the fuse need to be replaced an ASTA approved BS1362 fuse of the same rating must be used. Do not forget to refit the fuse cover. In the event of losing the fuse cover, the plug must not be used until a replacement fuse cover has been fitted. Colour of the replacement fuse cover must be the same colour as that visible on the pin face of the plug. Fuse covers are available from any good electrical store.

### Fiting a different plug

- As the colours of the wires in the mains lead of this appliance may not correspond with the coloured markings identifying the terminals on your plug, proceed as follows:
  - Brown cable = L (Live)
  - Blue cable = N (Neutral)
  - Green/yellow cable must be connected to ground (E)  $\equiv$  line

- With the alternative plugs a 13 A fuse must be fitted either in the plug or adaptor or in the main fuse box. If in doubt contact a qualified electrician.

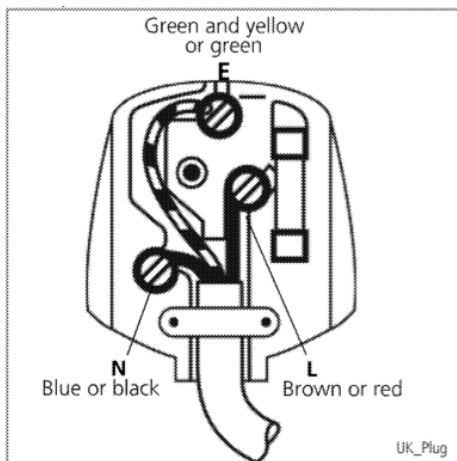

## 2 Box content

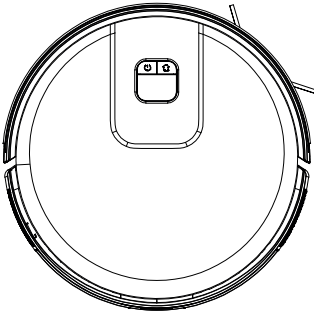

Robot Vacuum

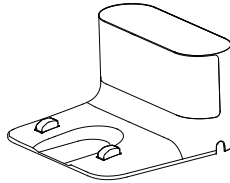

Charging dock

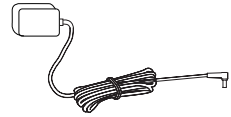

Charge adaptor

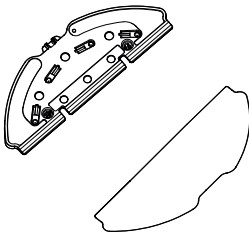

Mopping tool Mopping cloth



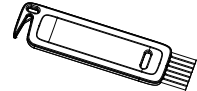

User's manual and product documentation (2 pcs)



Cleaning brush

### Spare accessories supplied

	1 side brush
	1 mopping cloth
	1 filter

# 3 Overview

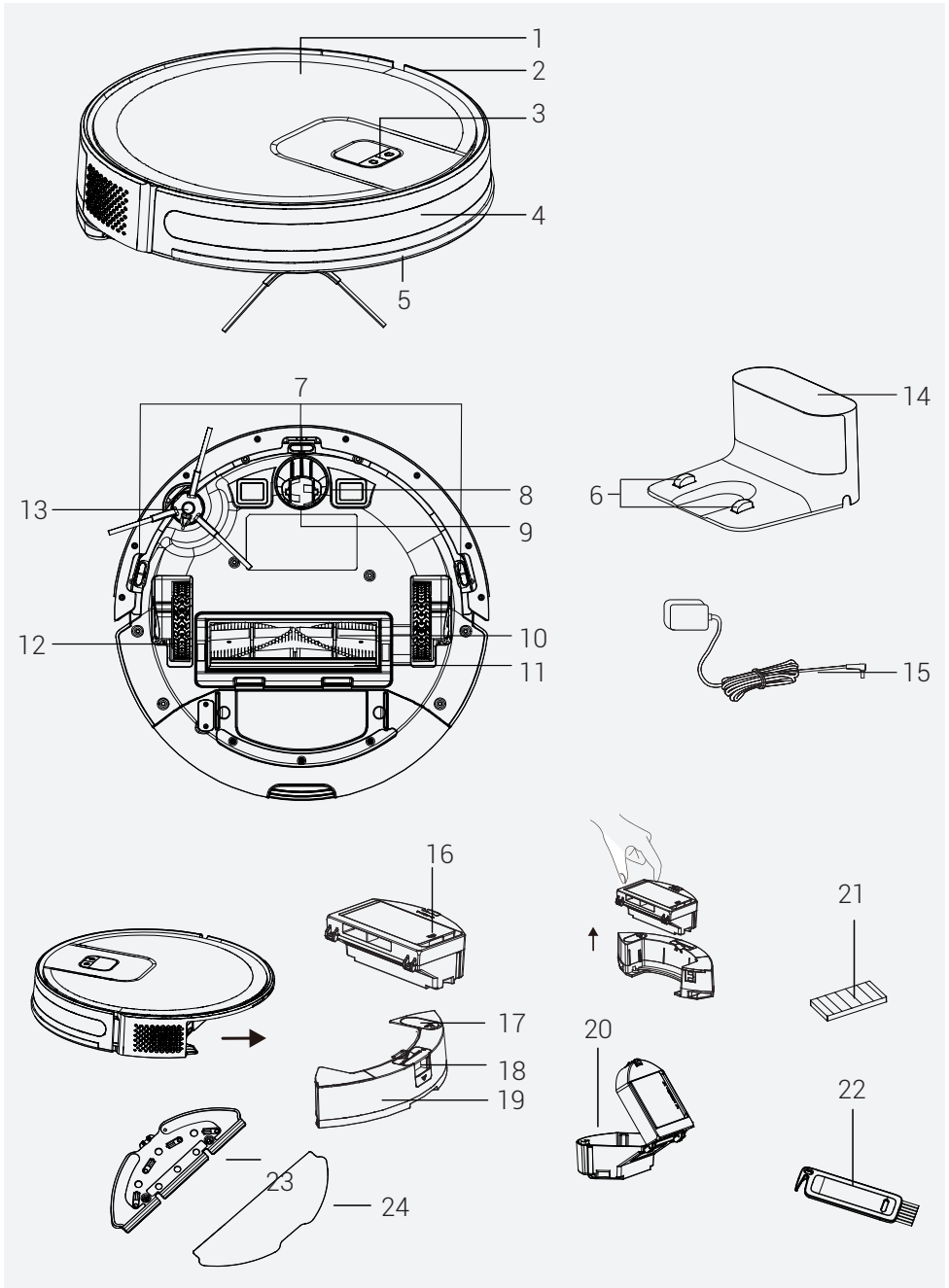

## 3 Overview

### 3.1 Checks and components

1. Upper body
2. Central body
3. Start Cleaning-Pause Button / Sending to Charging Stand button
4. Recharge Sensor
5. Front bumper
6. Charging pins
7. Fall prevention sensor
8. Charging pins
9. Front rotating wheel
10. Rotating brush
11. Rotating brush cover
12. Rear wheel
13. Side brush
14. Charging dock
15. Charge adaptor
16. Robot vacuum container EPA filter opening lid
17. Mop water container filling lid
18. Robot vacuum dust container ejection button
19. Mop water container
20. Dust container
21. EPA filter
22. Cleaning brush
23. Mopping tool
24. Mopping cloth

### 3.2 Technical data

<b>Adapter voltage</b>	100-240V~, 50/60 Hz
<b>Adapter output</b>	19 V 0.6 A
<b>Battery</b>	Li-ion: 14.4V / 2.6 Ah
<b>Charging period:</b>	4.5-5.5 hours
<b>Operation time</b>	Up to 150 minutes (in mute position)
<b>Dust container capacity</b>	0.4 L
<b>Water tank capacity</b>	0.3 L
<b>2.4G Wi-Fi frequency range</b>	2.400-2.4835 GHz
<b>Supported Connections</b>	WLAN IEEE 802.11 b/q/n wireless
<b>2.4G Wi-Fi maximum RF output power</b>	17.5 dBm
<b>RF exposure information</b>	2.4G Wi-Fi maximum
<b>2.4G Wi-Fi maximum RF output power</b>	13 dBm
<b>Operating time</b>	<b>Maximum:</b> 80 mins <b>Powerful:</b> 90 mins <b>Standard:</b> 120 mins <b>Quiet:</b> 150 mins

**RF exposure information** : The maximum allowed exposure level is calculated according to the 20 cm distance between the appliance and the human body. To comply with the RF exposure condition, a distance of 20 cm should be put between the appliance and the person.

The rights to make technical and design changes are reserved.

## 3 Overview

---

### Parameter of External Power Supply

<b>Manufacturer</b>	:	E-TEK Electronics Manufactory Co., LTD
<b>Model Identifier</b>	:	ZD012A190060BS
<b>Input Voltage</b>	:	100-240V~
<b>Input Frequency</b>	:	50/60Hz
<b>Input Current</b>	:	0.5A
<b>Output Voltage</b>	:	19.0V DC
<b>Output Current</b>	:	0.6 A
<b>Output Power</b>	:	11.4W
<b>Average active efficiency</b>	:	86.37%
<b>Efficiency at low load(10%)</b>	:	85.71%
<b>No-load power consumption</b>	:	0.074W

## 4 Installation

### 1- Remove the protective sponges.

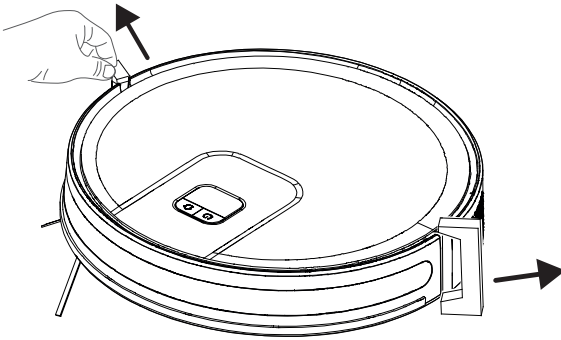

### 2- Remove the protective film

Remove the protective film on the front of the front impactbumper before use.

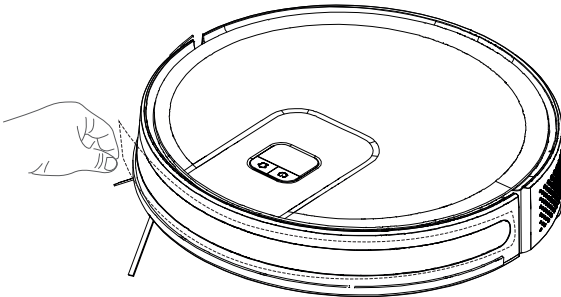

### 3- Install the side brush

Side brush installation: align the holes and press gently to fix the side brush on the device.

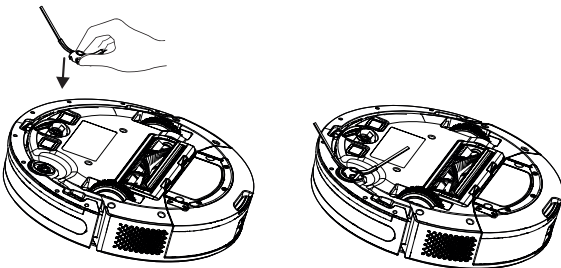

## 4 Installation

### 4- Install the charging station.

Install the adaptor plug to the charging station and set the cables up to prevent the adaptor cable from wrapping around the machine during vacuuming.

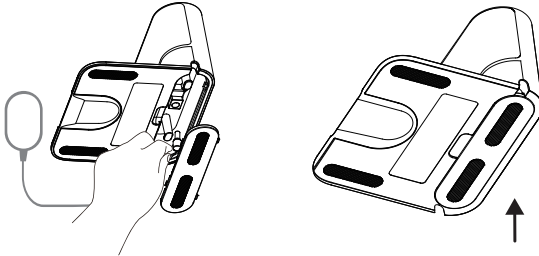

Install the charging station in a location where it can easily be accessed by the vacuum cleaner. Install the charging station on a hard and level ground rather than a carpet.

To ensure a smooth operation of the robot, it is advised that no obstacles are present within 1.5 m on the front and within 0.5 m on the left and right sides.

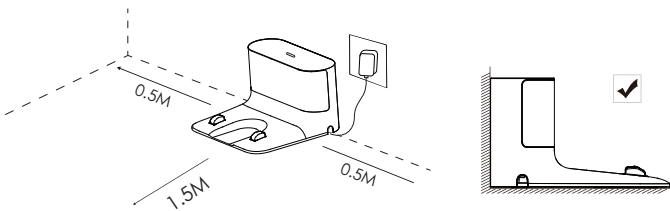

Always keep the charging station plugged, otherwise the robot vacuum cleaner cannot return to the charging station automatically.



For a smooth charging operation, do not move the charging station.





## 5 Operation



Please charge the machine before first use.

### 5.1 Intended use

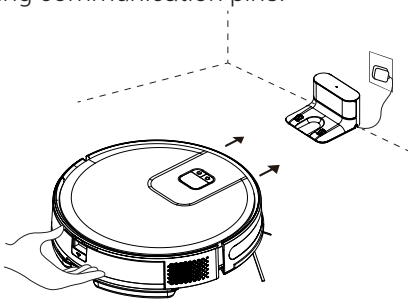

This appliance is intended for household use and it is not suitable for industrial use. Press and hold the  for 3 seconds to turn on. Press and hold the  for 3 seconds to turn off.

1. Place the appliance to the charging station so that it shall be aligned with the charging communication pins.





Charging starts when the white indicator on the charging station goes off, charging will begin.

### 5.2 Operation

Press and hold the  for 3 seconds to turn on. Press and hold the  for 3 seconds to turn off.

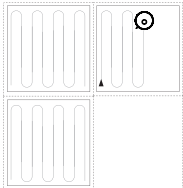
#### Starting the cleaning



Short press the  to start the automatic cleaning mode. The robot will leave the recharging dock after being turned on, clean in "Z" route, and then clean the area along the wall, and delimit another 4m x 4m area.

It repeats the above process continuously till cleaning of the whole room is completed, and additionally cleans areas uncovered in the process, and returns to the recharging dock after cleaning.

## 5 Operation



**WARNING:** If the charging level is too low, the cleaning cannot be started. Please charge the appliance before starting the cleaning.



**WARNING:** Before the cleaning, tidy up all cables to prevent disconnections due to entanglement/pulling of the cables and to prevent damage to the furniture.



**WARNING:** In the auto mode, by default the machine will do sweeping twice if the sweep duration is shorter than 10 minutes.



**WARNING:** Do not move the charging dock during cleaning and make sure that the station is plugged; otherwise the robot vacuum cleaner may not be able to return for recharging.

### Pausing

Pressing any button will stop the robot while working.

**Automatic charging:** The robot vacuum cleaner returns automatically to recharge after the cleaning is completed.

**Manual charging:** a. Please press  shortly when pausing to begin automatic recharging. b. Please manually put the robot back to recharging dock if the robot is stuck or cannot find the recharging dock.

## 5 Operation

### Spot Cleaning (supported with the relevant mobile application only)

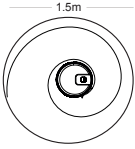

Move the sweeping robot to the area to be cleaned, press the  twice. After the mode is activated, the sweeping robot will sweep the circular area with a diameter of 1.5 m calculated from its own position.



The sweeping robot cannot enter the fixed-point sweeping mode on the recharging dock.

### Vacuum power selection

(Supported with the relevant mobile application only) You may select the desired cleaning power from the application:

- Quiet
- Standard
- Powerful
- Maximum

### Remote controlled cleaning

(Supported with the relevant mobile application only) You may direct the robot vacuum cleaner to the area to be cleaned by using the manual remote control mode through the application.

### Sleep

If it is inactive and the charging dock is not connected for 10 minutes, the machine will automatically switch to hibernation mode.

The robotic vacuum cleaner will switch to the sleep mode automatically if there is operation within 10 minutes after it is fully charged.

### Resetting the system

For APP account delete, the customer can press "remove the product and clear the account" button on the APP to delete all the data on the APP and cloud like clean histories, shared machine, WIFI account password...etc.

Press "" button for 15 seconds in standby position to reset the system. When the system is reset, the original settings on the robot vacuum cleaner are deleted.



## 5 Operation

### 5.2.1 Operation with the application

#### Download the application

To download the application, search for “HomeDirect-SDA” application in the mobile app store. Review the mobile application manual for detailed information.

#### Reset Wi-Fi

Press “” “” buttons simultaneously until you hear the aural warning and see the light blinking.

#### Add a device

- Open the app, create a new account and follow the instructions in the application.
- Before setting up the Wi-Fi, ensure that the robot vacuum cleaner and the Wi-Fi network meet the following requirements.

#### A. Robot Vacuum Cleaner:

- The charging level of the robot vacuum cleaner shall be over 20% or the robot vacuum cleaner shall be placed on the charging dock.

#### B. Wi-Fi network:

- Make sure the password of your wireless network (router) is correct.
- Do not use any VPN (Virtual private Network).
- Wi-Fi router shall support, 802.11b/g/n and IPv4 protocols.
- The router shall be in the 2.4GHz frequency band or a dual-band router that supports the 2.4GHz band shall be used. The robot vacuum cleaner does not support the 5GHz frequency band.
- If the robot vacuum cleaner cannot connect the 2.4/5GHz dual-band Wi-Fi network, please select 2.4GHz network for Wi-Fi settings. You may switch back to the other frequency band when the setting is completed.
- If you are connecting to a hidden network, please ensure that you enter the network name [SSID (sensitive to capitalization)] correctly and that you are connected to a 2.4GHz wireless network.
- If you are using a wireless network extender, please ensure that the network name (SSID) and the password are the same with the main network.

## 5 Operation

### Wi-Fi connection error

Wi-Fi Status Indicator	Cause	Solution
White indicator normally on	The robot has been connected to the router, but cannot connect to the network.	<ul style="list-style-type: none"><li>• Ensure that the modem is connected to the network.</li><li>• Contact your network operator to see if there is a problem in the internet data.</li></ul>
Flashing slowly in white	The robot cannot connect to your wireless router.	<ul style="list-style-type: none"><li>• Check whether the network name and password have changed.</li><li>• Reset Wi-Fi connections if necessary.</li></ul>
	Your Wi-Fi connection has been reset or not yet set previously.	<ul style="list-style-type: none"><li>• Establish Wi-Fi connection with the robot.</li><li>• Reset Wi-Fi connections if necessary.</li></ul>
Flashing rapidly in white	The robot cannot receive a network signal.	<ul style="list-style-type: none"><li>• Please clean up the electronic products around the robot.</li><li>• If necessary, please reset the WiFi and select the AP mode.</li></ul>

- If other operations are triggered during the networking process, the indicator light changes, and the device still maintains the network configuration status.
- If the connection between the mobile phone and the robotic vacuum cleaner fails, you can reset the Wi-Fi to enter the network configuration mode and add the device again.
- Due to version upgrades and updates, please follow the APP internal guide for actual operation.

## 5 Operation

### Network security requirements:

Use TKIP, PSK and AES/CCMP encrypted WPA and WPA2 networks.

### 5.3 Operation of the mop



**WARNING:** Do not use the mopping mode on a carpet.



**WARNING:** Do not put bleach or detergent in the water tank. These chemicals may damage the liquid channels that ensure the water flow in the robot vacuum cleaner or the pump.



**WARNING:** Remove the mopping unit while the robot vacuum cleaner is being charged or when it is not operated.



**WARNING:** Remove the mopping unit immediately after the mopping operation is completed to prevent damage to your wooden floors.



**WARNING:** The robot vacuum cleaner cuts off the water automatically when mopping is paused or ended. However, the mop remains wet and thus it shall not be kept at this condition for a long period and removed without delay.

# 5 Operation

## 5.3.1 Installation of the wet mopping unit

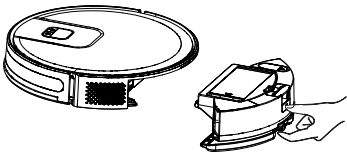

Remove the dust container and the water tank assembly (2 in 1).

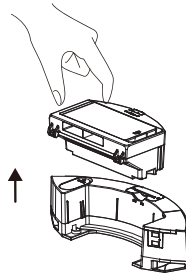

Remove the dust container.

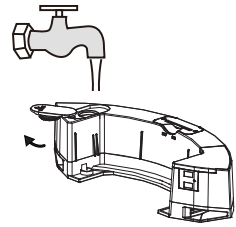

Remove the rubber plug and add water to the water tank from the water inlet.

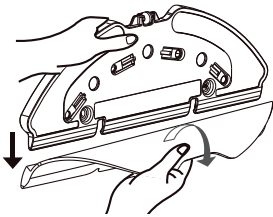

Remove the swab on the mop retainer as it is shown.

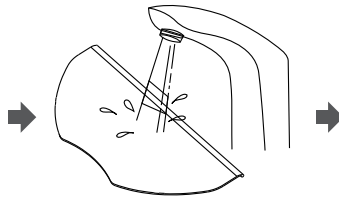

Moisten the swab before each mopping.

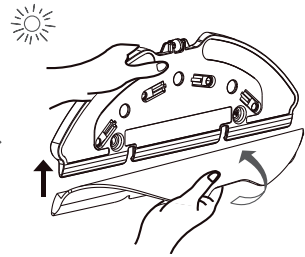

Place the swab to the mop retainer.

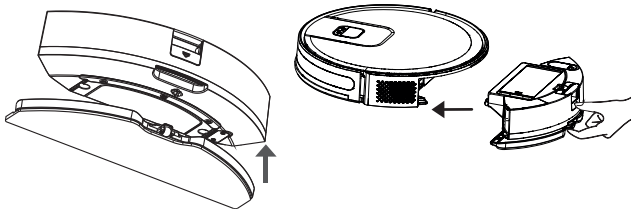

Install the mop retainer to the dust container and the water tank assembly (two in one) in the direction of the arrow.

Install the dust container and the water tank assembly (two in one) to the appliance, their places in the direction of the arrow.

## 5 Operation

### 5.3.2 Wet mopping setting

You may start the cleaning operation by selecting the cleaning mode and set the level of wetness during mopping as desired in the application.

It is suggested remove carpets from the floor to prevent the device from wetting the carpet when mopping the floor.

## 6 Cleaning and maintenance

Turn off the appliance and unplug it before cleaning it.



**WARNING:** Never use gasoline, solvent, abrasive cleaners, metal objects or hard brushes to clean the appliance.

### 6.1 Cleaning the dust container and filters



You may call our call center to order a new filter when your filter reaches the end of its expected life, is deformed or needs to be replaced for a reason.



To achieve the maximum performance with EPA filter, clean it with a brush after each cleaning.

EPA filter is a replaceable accessory.

If you performed a cleaning operation in a space where there is construction dust and dust with very tiny particles, replace your filter with a new one in order not to experience a loss of performance.

1. Remove the dust container and the water tank assembly (2 in 1) by pressing the button as shown below.

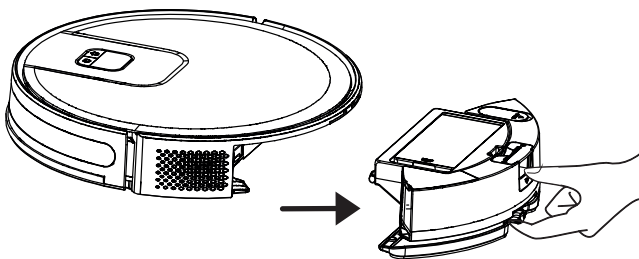



## 6 Cleaning and maintenance

2. Remove the dust container by pulling it in the direction of the arrow.

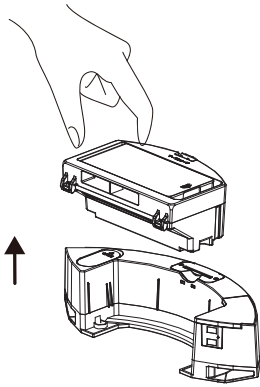

3. Open the dust container as it is seen below and empty it as it is shown.

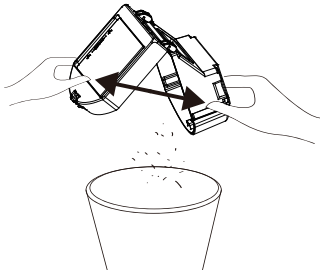

4. Remove the high performance filter and clean the filter using the cleaning brush provided together with the appliance.

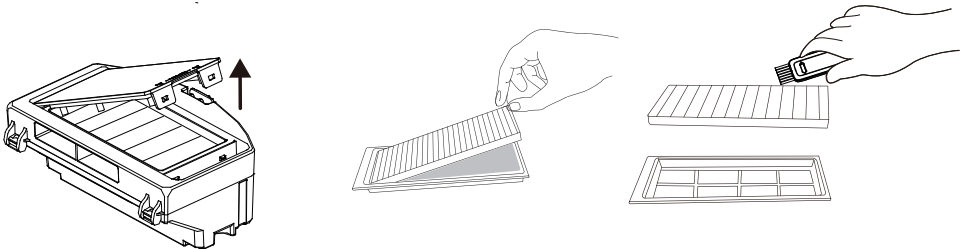

## 6 Cleaning and maintenance

5. Wash the water tank, dust container and filter assembly periodically with **cold water** as required as per the frequency of operation.

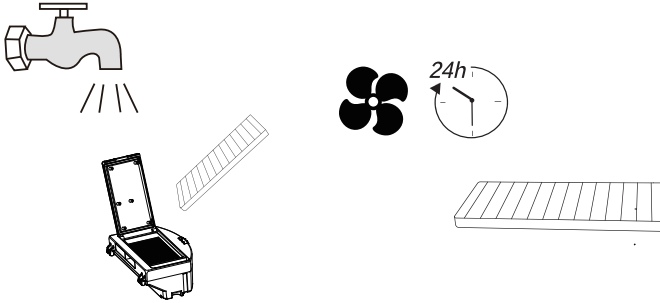

6. Leave the water tank, dust container and filter assembly to dry after washing, and ensure that they are completely dried.



Drying may take 24 to 48 hours.

7. Assemble the water tank, dust container and filter assembly after drying them and then install the assembly to the vacuum cleaner.



**WARNING:** Do not operate the robot vacuum cleaner without installing the filter group. Otherwise, the appliance may get damaged.

### 6.2 Cleaning of the brush

1. Open the upper cover of the main brush by pressing on the tabs. Pull and remove the main roll upwards. Cut the hair lapped on the roller brush with the cutting and sharp side of the cleaning brush. Then clean the dusts on the roller brush with the bristles of the cleaning brush.

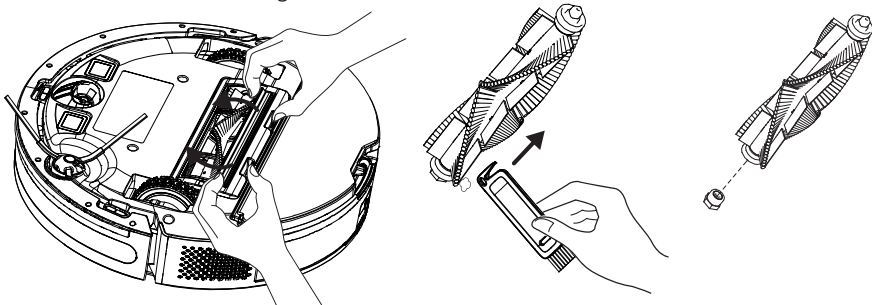

## 6 Cleaning and maintenance

2. Replace the brush after cleaning it and close the cover in the direction of the arrow.

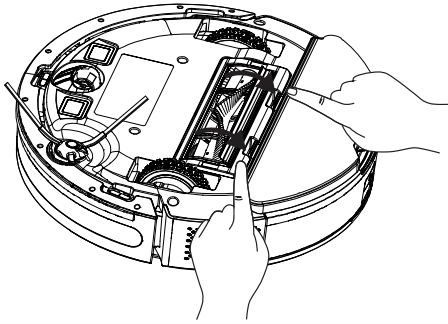

### 6.3 Cleaning and installation of the side brush

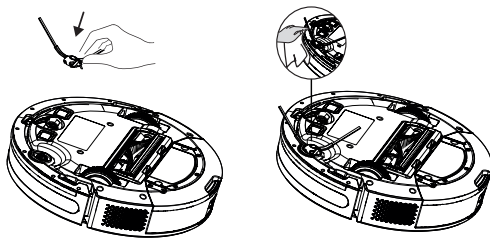

In the long term use, wash the side brush with warm water in order to eliminate the shape deformation. Install it to the robot as it is shown after it has dried.

### 6.4 Cleaning of the Sensors & Front wheel

Clean the sensors and charging pins/electrodes regularly and remove the dust using a dry and soft cloth or a cleaning brush.

Information: You get a notification via the application when sensor cleaning is required.

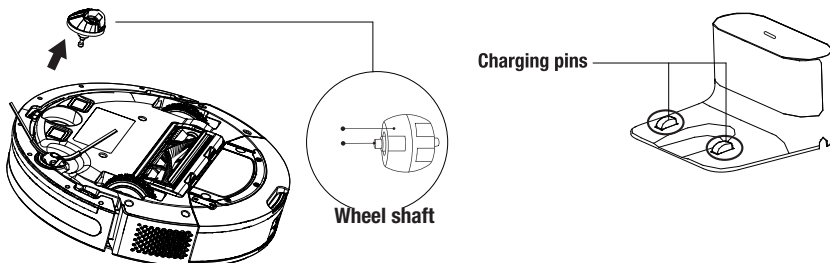

## 6 Cleaning and maintenance

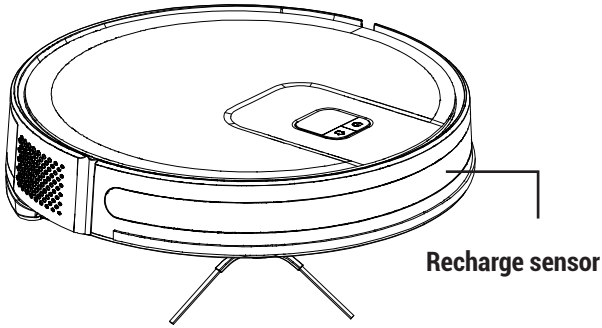

Fall prevention sensor

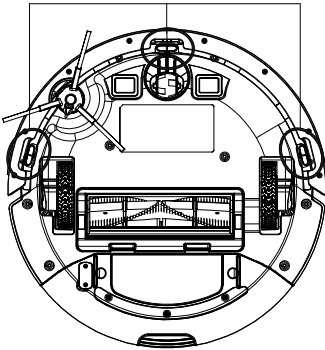

## 6 Cleaning and maintenance

### 6.5 Cleaning of the mopping unit

We recommend that you remove the mop holder from one side, drain the water tank, rinse the mop with water and then leave it to dry after each operation of the mopping unit. You may wash the mop in a washing machine.

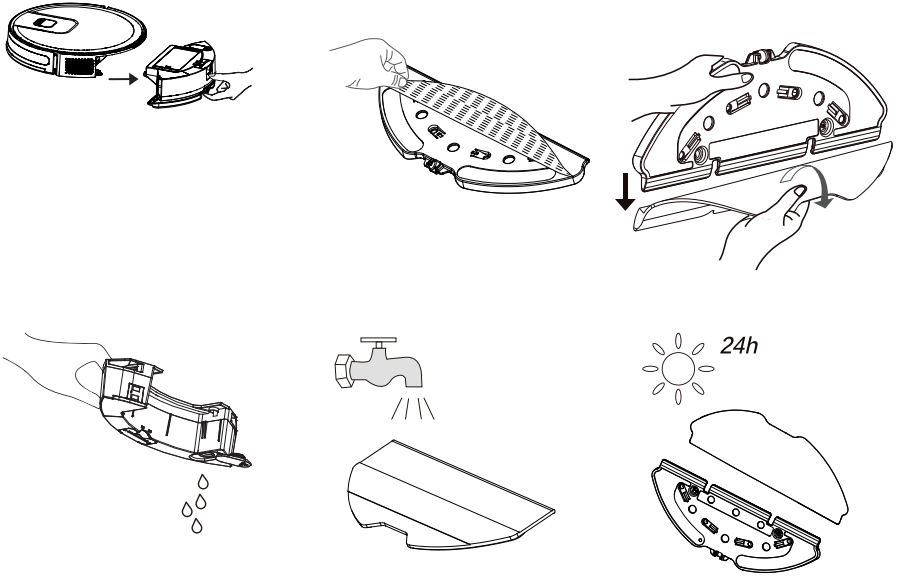

# 7 Troubleshooting

## Troubleshooting

The power indicator will flash in red and the buzzer will give a beep in case that there is an abnormality in the operation of the sweeping robot. Please check the table below to solve your problems.

Voice Prompts	Solution
The robot cannot start.	<ul style="list-style-type: none"><li>- Make sure the robot is connected to power supply.</li><li>- Make sure the battery is fully charged.</li><li>- If the problem persists, please reset the robot .</li></ul>
The robot suddenly stops working.	<ul style="list-style-type: none"><li>- Check whether the robot is stuck or blocked by obstacles.</li><li>- Check whether the battery is too low.</li><li>- If the problem persists, please shut it down, wait for 3 seconds, and then restart it.</li></ul>
Cannot make a sweep schedule	<ul style="list-style-type: none"><li>- There are too many obstacles around the charging dock. Please place the charging dock to an area free of obstacles.</li><li>- The robot vacuum cleaner is too far away from the charging dock. Bring the robot vacuum cleaner closer to the charging dock and try again.</li><li>- Make sure that the charging stand station is plugged and there is energy.</li></ul>
Suction too weak	<ul style="list-style-type: none"><li>- Check the suction inlet for any obstruction.</li><li>- Empty the dustbin.</li><li>- Clean filters with water.</li><li>- Check whether filters are wet due to water or other liquids on the floor. Let filters dry naturally thoroughly before use.</li></ul>
Cannot charge the machine	<ul style="list-style-type: none"><li>- Please check whether the charging dock is correctly connected to the power supply, and the indicator light illuminates when the power is on.</li><li>- When the robot is normally connected to the charging dock, the indicator light extinguishes.</li><li>- If the robot is connected to the charging dock, but the indicator light does not extinguish and the robot does not respond, please use a dry cloth to wipe the charging pole piece at the bottom of the robotic vacuum cleaner and the charging piece of the charging dock, and then try again.</li><li>- If the robot still can not be charged after performing the above operations, please contact the after-sales department or your dealer.</li></ul>

## 7 Troubleshooting

### Troubleshooting

The power indicator will flash in red and the buzzer will give a beep in case that there is an abnormality in the operation of the sweeping robot. Please check the table below to solve your problems.

Voice Prompts	Solution
The robot cannot return to the charging dock.	<ul style="list-style-type: none"><li>- Clear the charging dock of objects within 0.5m on the left and right sides and within 1.5m ahead.</li><li>- Make sure that the robot starts sweep from the charging dock without abnormal movement.</li><li>- When the robot is near the charging dock, it can return faster. But if the charging dock is located far away, the robot will need more time to return.</li><li>- Please wait during its return.</li><li>- Clean charging electrodes.</li></ul>
The rolling brush does not rotate	<ul style="list-style-type: none"><li>- Clean the rolling brush.</li><li>- Check whether the main brush and the main brush cover are installed correctly.</li></ul>
Abnormal action or sweep route of the robot	<ul style="list-style-type: none"><li>- Carefully clean the sensor with dry cloth.</li><li>- Restart the robot.</li></ul>
No water released during mopping	<ul style="list-style-type: none"><li>- Make sure there is enough water in the water tank.</li><li>- Check whether the mop module is installed correctly. Upon correct installation, you will hear related voice prompt.</li><li>- Check whether the water outlet is blocked.</li></ul>
The machine cannot connect to your Wi-Fi network.	<ul style="list-style-type: none"><li>- Ensure that your Wi-Fi router supports 2.4GHz and 802.11b/g/n bands as this equipment does not support 5GHz bands. For more details, please refer to the "Faults in Wi-Fi Connection" section herein.</li></ul>



Please contact our customer service promptly if any fault cannot be eliminated with the above measures.

## Product Guarantee

### **12 months breakdown and repair guarantee**

Guarantor: **Beko plc, 1 Greenhill Crescent, Watford, Hertfordshire. WD18 8UF**

The guarantee does not in any way diminish your statutory or legal rights.

Your **appliance** has the benefit of our manufacturer's guarantee which covers the product for 12 months from the date of original purchase.

This gives you reassurance that if within that time, your **appliance** is proven to be defective because of either workmanship or materials, we will at our discretion either repair or replace your **appliance**.

The **appliance** must be correctly installed, located and operated in accordance with the instructions contained in the user manual. The guarantor disclaims any liability for accidental or consequential damage.

#### The Guarantee is subject to the following conditions:

- Documentary proof of the original purchase date is provided.
- The appliance has been installed and operated correctly and in accordance with our operating and maintenance instructions.
- The appliance is used only on the electricity supply on the rating plate.
- The appliance has only been used for normal domestic purposes.
- The appliance has not been altered, serviced, dismantled or otherwise interfered with by any person.
- The appliance is used in the United Kingdom or Republic of Ireland.
- Any parts removed during repair work or any product that has been replaced becomes our property.
- The guarantee is not transferrable if the product is resold.

#### The Guarantee does not cover:

- Transit, installation or delivery damage.
- Accidental damage.
- Misuse or abuse.
- Replacement of any consumable item or accessories. These include but are not limited to: plugs, cables, light bulbs, knobs, filters and flaps.
- Repairs or replacements required as a result of unauthorised repairs or inexperienced installation that fails to meet the requirements contained in the user guide or instruction book.
- Repairs to products used in commercial or non-residential household premises.

### **How to obtain after sales service, help or general advice**

**Please keep your purchase receipt or other proof of purchase in a safe place as you will need to show us this document if your product requires attention within the guarantee period.**

Please also record your product details below, which will allow you to access our services more quickly and help us identify your product. The model number is printed on the front of the user guide and the serial and model number is shown on your products rating plate.

<b>Model number</b>	<b>Serial number</b>	<b>Purchased from</b>	<b>Date of purchase</b>

Please call our UK based Customer Service department if you need help or advice from us:

United Kingdom and Northern Ireland: **0333 207 9710**

Republic of Ireland: **01 862 3411**

You can also contact us through our website: **[www.beko.co.uk](http://www.beko.co.uk)**



Arçelik A.Ş.  
Karaağaç Caddesi No: 2-6, 34445,  
Sütlüce/ İSTANBUL/ TÜRKİYE  
[www.beko.co.uk](http://www.beko.co.uk)