BEKO

70cm Glass Chimney Hood

Model: HBG70X

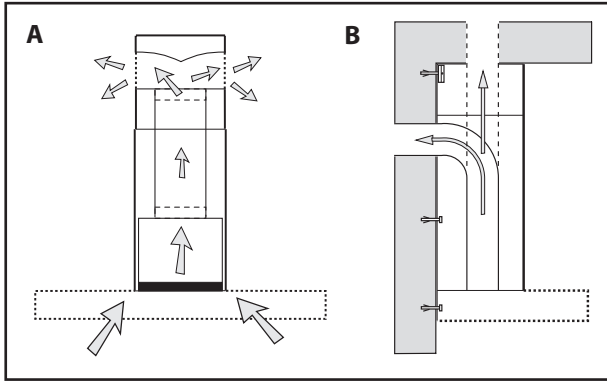

Fig.1

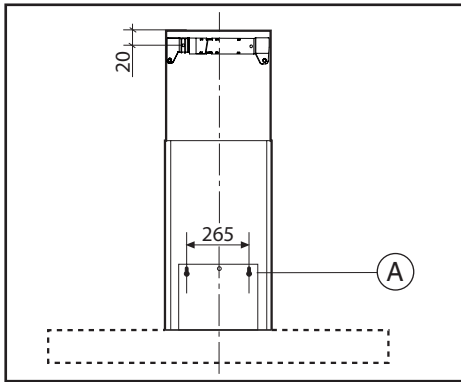
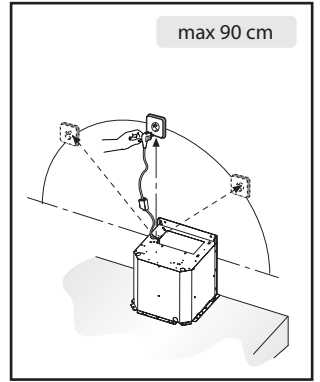

Fig.2

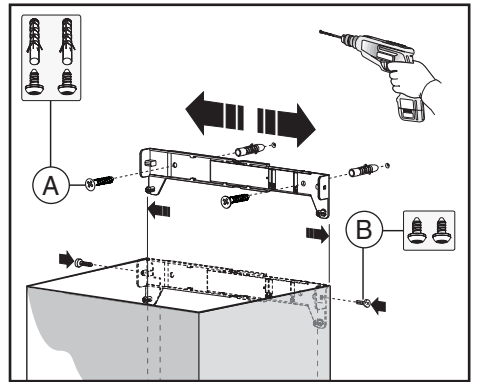

Fig.3

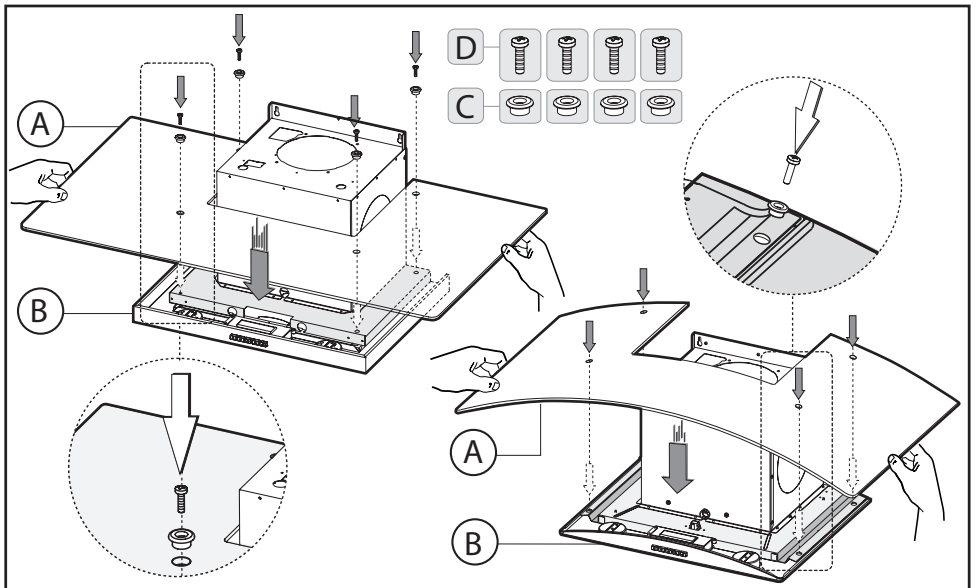

Fig.4

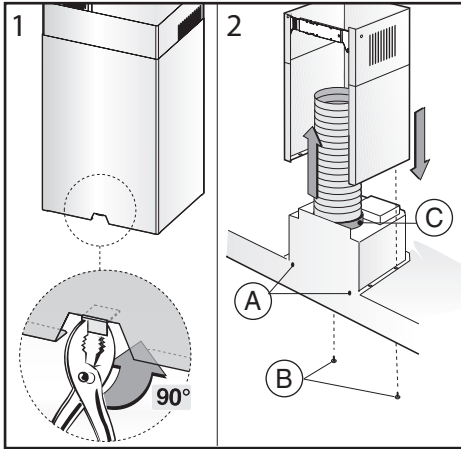

Fig.5

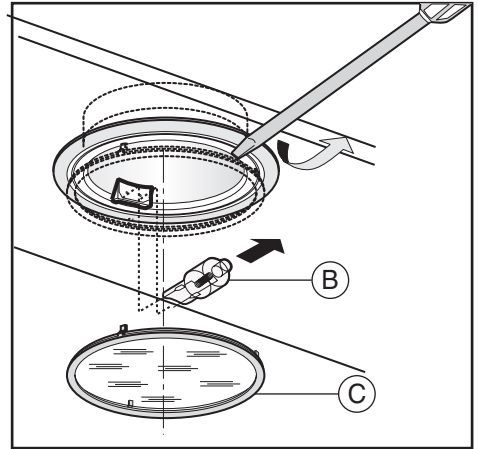

Fig.6

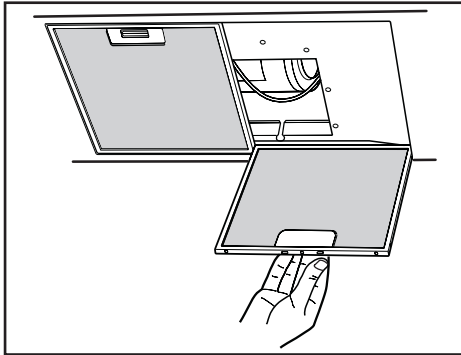

Fig.7

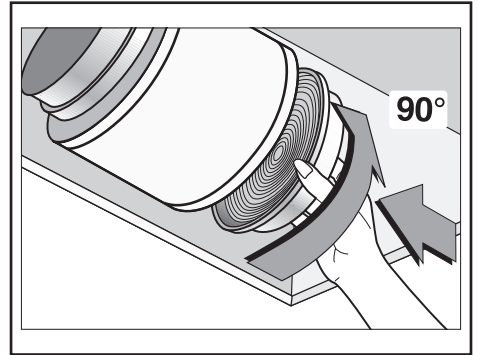

Fig.8

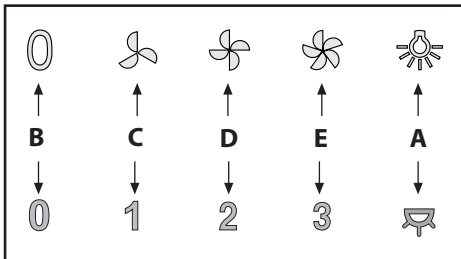

Fig.9

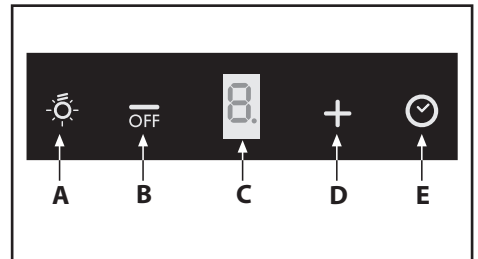

Fig.11

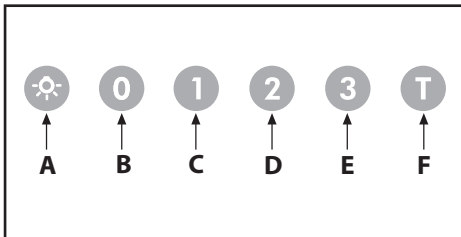

Fig.10

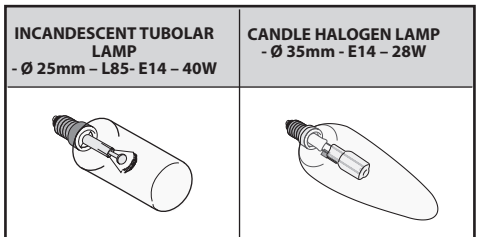

Fig.12

GENERAL

Carefully read the following important information regarding installation safety and maintenance. Keep this information booklet accessible for further consultations. The appliance has been designed for use in the ducting version (air exhaust to the outside – Fig.1B), filtering version (air circulation on the inside – Fig.1A) or with external motor (Fig.1C).

SAFETY PRECAUTION

1. Take care when the cooker hood is operating simultaneously with an open fireplace or burner that depend on the air in the environment and are supplied by other than electrical energy, as the cooker hood removes the air from the environment which a burner or fireplace need for combustion. The negative pressure in the environment must not exceed 4Pa (4x10⁻⁵ bar). Provide adequate ventilation in the environment for a safe operation of the cooker hood. Follow the local laws applicable for external air evacuation.

Before connecting the model to the electricity network:

- Control the data plate (positioned inside the appliance) to ascertain that the voltage and power correspond to the network and the socket is suitable. If in doubt ask a qualified electrician.
- If the power supply cable is damaged, it must be replaced with another cable or a special assembly, which may be obtained direct from the manufacturer or from the Technical Assistance Centre.
- This device must be hardwired to the mains supply network by connecting to a single phase spur protected by **3A fuse**.

2. Warning!

In certain circumstances electrical appliances may be a danger hazard.

- A) Do not check the status of the filters while the cooker hood is operating.**
- B) Do not touch bulbs or adjacent areas, during or straight after prolonged use of the lighting installation.**
- C) Flambè cooking is prohibited underneath the cooker hood.**
- D) Avoid free flame, as it is damaging for the filters and a fire hazard.**
- E) Constantly check food frying to avoid that the over-heated oil may become a fire hazard.**
- F) Disconnect the electrical plug prior to any maintenance.**
- G) This appliance is not intended for use by young children or infirm persons without supervision.**
- H) Young children should be supervised to ensure they do not play with the appliance.**
- I) There shall be adequate ventilation of the room when the rangehood is used at the same time as appliances burning gas or other fuels.**
- L) There is a risk of fire if cleaning is not carried out in accordance with the instructions.**

This appliance conforms to the European Directive EC/2002/96, Waste Electrical and Electronic Equipment (WEEE). By making sure that this appliance is disposed of in a suitable manner, the user is helping to prevent potential damage to the environ-

ment or to public health.





The symbol on the product or on the accompanying paperwork indicates that the appliance should not be treated as domestic waste, but should be delivered to a suitable electric and electronic appliance recycling collection point. Follow local guidelines when disposing of waste. For more information on the treatment, re-use and recycling of this product, please contact your local authority, domestic waste collection service or the shop where the appliance was purchased.

INSTALLATION INSTRUCTIONS

- **Assembly and electrical connections must be carried out by specialised personnel.**
- **Wear protective gloves before proceeding with the installation.**

• Electric Connection

Note: Verify the data label placed inside the appliance:

- If the symbol  appears on the plate, it means that no earth connection must be made on the appliance, therefore follow the instructions concerning insulation class II.
- If the symbol  DOES NOT appear on the plate, follow the instructions concerning insulation class I.

Insulation class II

The appliance has been manufactured as a class II, therefore no earth cable is necessary.

The plug must be easily accessible after the installation of the appliance. If the appliance is equipped with power cord without plug, a suitably dimensioned omnipolar switch with 3 mm minimum opening between contacts must be fitted between the appliance and the electricity supply in compliance with the load and current regulations.

The connection to the mains is carried out as follows:

BROWN = **L** live wire

BLUE = **N** neutral

Insulation class I

This is a **class I**, appliance and must therefore be connected to an efficient earthing system.

The appliance must be connected to the electricity supply as follows:

BROWN = **L** live wire

BLUE = **N** neutral

YELLOW/GREEN =  earth

The neutral wire must be connected to the terminal with the **N** symbol while the **YELLOW/GREEN**, wire must be connected to the terminal by the earth symbol .

Warning:

When connecting the appliance to the electricity supply, make sure that the mains socket has an earth connection. After fitting the ducted cooker hood, make sure that the electrical plug is in a position where it can be accessed easily. If the appliance is connected directly to the electricity supply, an omnipolar switch with a minimum contact opening of 3 mm must be placed in between the two; its size must be suitable for the load required and it must comply with current legislation.

- The minimum distance between the support surfaces of

the cooking pots on the cooker top and the lowest part of the cooker hood must be at least 65 cm. If a connection tube composed of two parts is used, the upper part must be placed outside the lower part. Do not connect the cooker hood exhaust to the same conductor used to circulate hot air or for evacuating fumes from other appliances generated by other than an electrical source. Before proceeding with the assembly operations, remove the anti-grease filter(s) (Fig.7) so that the unit is easier to handle. In the case of assembly of the appliance in the suction version prepare the hole for evacuation of the air.

• We recommend the use of an air exhaust pipe with a diameter of 150. If a pipe with a smaller diameter is used, the efficiency of the product may be reduced and its operation may become noisier.

Please note:

If your version of the appliance has decorative glass before installing the hood, carry out the following steps as shown in **figure 4**:

1 - Remove both the cooker hood body **B** and the glass panel **A** from the packaging and place them horizontally on a secure surface.

2 - Take the glass panel **A** and position it above the cooker hood body **B**.

3 - Fix the glass panel securely to the cooker hood body using the 4 sleeves **C** and 4 screws **D** as indicated.

• Fixing to the wall

Drill the holes **A** respecting the distances indicated (Fig.2). Fix the appliance to the wall and align it in horizontal position to the wall units. When the appliance has been adjusted, definitely fix the hood using the screws **A** (Fig.5). For the various installations use screws and screw anchors suited to the type of wall (e.g. reinforced concrete, plasterboard, etc.). If the screws and screw anchors are provided with the product, check that they are suitable for the type of wall on which the hood is to be fixed.

• Fixing the decorative telescopic flue

Warning! Caution! If your appliance model features the lower connector with a tab, before fixing it in place bend the tab inwards using a pair of pliers, as illustrated in **figure 5, step 1**. Arrange the electrical power supply within the dimensions of the decorative flue. If your appliance is to be installed in the ducting version or in the version with external motor, prepare the air exhaust opening. Adjust the width of the support bracket of the upper flue (Fig.3). Then fix it to the ceiling using the screws **A** (Fig.3) in such a way that it is in line with your hood and respecting the distance from the ceiling indicated in Fig.2. Connect the flange **C** to the air exhaust hole using a connection pipe (Fig.5 - Stage 2). Insert the upper flue into the lower flue. Fix the lower flue to the hood using the screws **B** provided (Fig.5 - Stage 2), extract the upper flue up to the bracket and fix it with the screws **B** (Fig.3). To transform the hood from a ducting version into a filtering version, ask your dealer for the charcoal filters and follow the installation instructions.

• Filtering version

Install the hood and the two flues as described in the paragraph for installation of the hood in ducting version. To assemble the filtering flue refer to the instructions contained in the kit.

If the kit is not provided, order it from your dealer as accessory.

The filters must be applied to the suction unit positioned inside the hood. They must be centred by turning them 90 degrees until the stop catch is tripped (Fig.8).

USE AND MAINTENANCE

• We recommend that the cooker hood is switched on before any food is cooked. We also recommend that the appliance is left running for 15 minutes after the food is cooked, in order to thoroughly eliminate all contaminated air.

The effective performance of the cooker hood depends on constant maintenance; the anti-grease filter and the active carbon filter both require special attention.

• **The anti-grease filter** is used to trap any grease particles suspended in the air, therefore is subject to saturation (the time it takes for the filter to become saturated depends on the way in which the appliance is used).

- To prevent potential fire hazards, the anti-grease filters should be washed a minimum of every 2 months (it is possible to use the dishwasher for this task).

- After a few washes, the colour of the filters may change. This does not mean they have to be replaced.

If the replacement and washing instructions are not followed, the anti-grease filters may present a fire hazard.

• **The active carbon filters** are used to purify the air which is released back into the room. The filters are not washable or re-usable and must be replaced at least once every four months. The active carbon filter saturation level depends on the frequency with which the appliance is used, the type of cooking performed and the regularity with which the anti-grease filters are cleaned.

• Clean the cooker hood frequently, both inside and outside, using a cloth which has been dampened with denatured alcohol or neutral, **non**-abrasive liquid detergents.

• The light on the cooker hood is designed for use during cooking and not for general room illumination. Extended use of the light reduces the average duration of the bulb.

• Replacing halogen light bulbs (Fig.6)

To replace the halogen light bulbs **B**, remove the glass pane **C** using a lever action on the relevant cranks.

Replace the bulbs with new ones of the same type.

Caution: do not touch the light bulb with bare hands.

Replace incandescent/halogen/fluorescent lamps (Fig.12):

only use lamps of the same type and Wattage installed on the device.

• **Commands** (Fig.9) mechanical the key symbols are explained below:

A = LIGHT

B = OFF

C = SPEED I

D = SPEED II

E = SPEED III.

• **Commands** (Fig.10) **luminous** the key symbols are explained below:

A = LIGHT

B = OFF

C = SPEED I

D = SPEED II

E = SPEED III

F = AUTOMATIC STOP TIMER - 15 minutes (*).

• If your appliance does not have the **INTENSIVE** speed function, press key **E** for two seconds and it will be activated for 10 minutes after which it will return to the previously set speed. When the function is active the LED flashes. To interrupt it before the 10 minutes have expired press key **E** again.

• By pressing key **F** for two seconds (with the hood switched off) the “**clean air**” function is activated. This function switches the appliance on for ten minutes every hour at the first speed. As soon as this function is activated the motor starts up at the first speed for ten minutes. During this time key **F** and key **C** must flash at the same time. After ten minutes the motor switches off and the LED of key **F** remains switched on with a fixed light until the motor starts up again at the first speed after fifty minutes and keys **F** and **C** start to flash again for ten minutes and so on.

By pressing any key for the exclusion of the hood light the hood will return immediately to its normal functioning (e.g. if key **D** is pressed the “**clean air**” function is deactivated and the motor moves to the 2nd speed straight away. By pressing key **B** the function is deactivated).

(*) The “**AUTOMATIC STOP TIMER**” delays stopping of the hood, which will continue functioning for 15 minutes at the operating speed set at the time this function is activated.

• **Active carbon/grease filter saturation:**

- When button **A** flashes at a frequency of **2 seconds**, the **grease** filters must be cleaned.

- When button **A** flashes at a frequency of **0.5 seconds**, the **carbon** filters must be replaced.

After the clean filter has been replaced, the electronic memory must be reset by pressing button **A** for approximately **5 seconds**, until the light on the button stops flashing.

• **Commands:** (Fig.11)

Push-button A = on/off lights switch.

Push-button B = on/off cooker hood switch. The appliance switches on at speed level 1, If the cooker hood is on depress the push-button for 2 sec. to switch off the cooker hood. If the cooker hood is at speed level 1 it will not be necessary to depress the push-button to switch the cooker hood off. Decreases the motor speed.

Display C = indicates the motor speed level selected and activates the timer.

Push-button D = switches on the cooker hood. Increases the motor speed. Touching the key at 3rd speed, the intensive function runs for 10; then the appliance go back to work at the original speed. During this function the display blinks.

Key E = The Timer times the functions on activation for 15 minutes, after which they are switched off. The Timer is deactivated by re-pressing **Key E**.

When the Timer is activated the decimal point must flash on the display. The Timer cannot be activated if the intensive speed is functioning.

The “**clean air**” function is activated by pressing key **E** for 2 seconds when the appliance is switched off. This switches the motor on for 10 minutes every hour at the first speed.

During functioning a rotary movement of the peripheral segments must be visualised on the display. When this time has passed the motor switches off and the fixed letter “**C**” must be visualised on the display until the motor re-starts after 50 minutes for another 10 minutes and so on.

Press any key apart from the light keys to return to normal functioning. Press key **E** to deactivate the function.

• **Active carbon/grease filter saturation:**

- When display item **C** flashes, at a speed where it alternates with the letter **F** (e.g. 1 and **F**), the **grease** filters must be washed.

- When display item **C** flashes, at a speed where it alternates with the letter **A** (e.g. 1 and **A**), the **carbon** filters must be replaced.

After the clean filter has been positioned correctly, the electronic memory must be reset by pressing button **A** for approximately **5 seconds**, until the indication **F** or **A** shown on the display **C** stops flashing.

• **FILTER REMOVAL**

WARNING - ENSURE THE APPLIANCE IS SWITCHED OFF AT THE MAINS BEFORE REPLACING THE BULBS AND FILTERS.

1. remove the filters by lifting the recessed handle and lift free from the hood frame.

2. To reinstall the filters position in the recess at the rear and press to lock in position.

BULB REPLACEMENT

1. Remove the filters

2. Unscrew the bulb in an anti-clock wise direction.

3. After installing the correct replacement bulb, refit the filter.

Replacement bulbs can be easily obtained from a good electrical or DIY store.

BEFORE CALLING SERVICE/TROUBLE SHOOTING

The hood was switched on but the unit does not operate.

• Have you plugged in/switched on the power supply at the socket?

• Check for a blown fuse/or trip.

Extraction is poor

• Check and clean the filters if required, if required, if active filters are present replacement filters maybe required.

• Check that the exhaust ducting is not obstructed.

THE MANUFACTURER DECLINES ALL RESPONSIBILITY FOR EVENTUAL DAMAGES CAUSED BY BREACHING THE ABOVE WARNINGS.

Guarantee and Service

Your Beko product is guaranteed against the cost of breakdown repairs for twelve months from the date of the original purchase.

What is covered?

- All repairs necessary as a result of faulty materials, defective components or manufacturing defect.
- The cost of all functional replacement parts.
- The labour costs of a Beko approved repairer to carry out the repair

What is not covered?

- Transit or delivery damage
- Accidental damage
- Misuse, or abuse.
- Cabinet or appearance parts, including knobs and flaps
- Accessory items, including ice trays, scrapers, cutlery baskets
- Repairs required as a result of unauthorised repairs or inexperienced installation that fails to meet the requirements contained in the user instruction book.
- Repairs to products used on commercial or non-residential household premises

Important notes.

- The product is guaranteed for domestic household use only.
- The guarantee will be void if the product is installed or used in commercial or non-residential household premises.
- The product must be correctly installed, located and operated in accordance with the instructions contained in the User Instruction Booklet provided.
- Professional Installation by a qualified plumber/electrical appliance installer is recommended for all Washing & Dishwashing Machines and Electric Cookers
- Gas appliances must only be installed by a Gas Safe (or BORD GAIS) registered Gas Installer.
- The guarantee is given only within the boundaries of the United Kingdom.
- The guarantee is not transferable if the product is resold.
- Beko plc disclaims any liability for incidental or consequential damages
- The guarantee does not in anyway diminish your statutory or legal rights.

HOW TO OBTAIN SERVICE UNDER THE MANUFACTURERS WARRANTY

Please keep your purchase receipt or other proof of purchase in a safe place; you will need to have it should the product require attention in the guarantee period

You should also complete the details below; it will help us assist you quicker when requesting service. (The model number is printed on the Instruction Booklet)

Model Number:

Purchased From:

Date of Purchase:

For service under guarantee simply telephone the appropriate number below

UK Mainland & Northern Ireland

Fridges & Freezers

0845 600 4903/0345 600 4903

Electric Cookers

0845 600 4902/0345 600 4902

Gas & Dual Fuel Cookers

0845 600 4905/0345 600 4905

Washing Machines & Dishwashers

0845 600 4906/0345 600 4906

Republic of Ireland

All Refrigeration, Cooking, Washing & Dishwashing Machines

01 862 3411

Before requesting service please check the trouble-shooting guide in the Operating Instructions as a charge may be levied where no faults is found even though your product may still be under guarantee.

Service once the manufacturers guarantee has expired:

If you have purchased an extended guarantee please refer to the instructions contained within the extended guarantee agreement document. Otherwise please call the above numbers where service can be obtained at a charge.

Should you experience any difficulty in obtaining service please call the

Beko Customer Help-Line on 0845 600 4911/0345 600 4911

Beko House, 1 Greenhill Crescent, Watford, Herts. WD18 8QU



3LIK16xx