

# Cooker hood

User manual

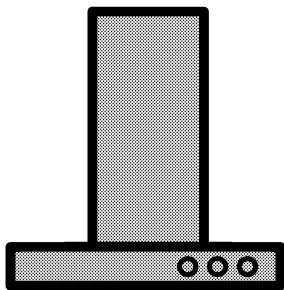

HCB63744BX

**EN**

185.7301.46/R.AB/28.12.2016

## Please read this user manual first!

Dear Customer,

Thank you for purchasing this Beko product. We hope that you get the best results from your product which has been manufactured with high quality and state-of-the-art technology. Therefore, please read this entire user manual and all other accompanying documents carefully before using the product and keep it as a reference for future use. If you handover the product to someone else, give the user manual as well. Follow all warnings and information in the user manual.

Remember that this user manual is also applicable for several other models. Differences between models will be identified in the manual.

### Explanation of symbols

Throughout this user manual the following symbols are used:

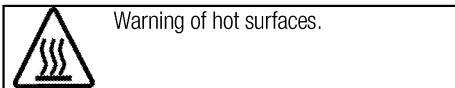
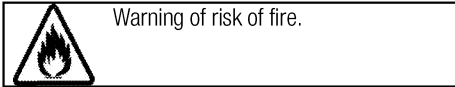
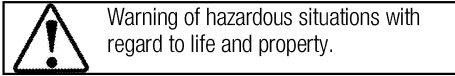
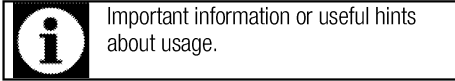

**Arçelik A.Ş.**  
Karaağaç caddesi No:2-6  
34445 Sütlüce/İstanbul/TURKEY  
Made in TURKEY



This product was manufactured using the latest technology in environmentally friendly conditions.

## TABLE OF CONTENTS

<b>1 Important instructions and warnings for safety and environment</b>	<b>4</b>	<b>3 Installation</b>	<b>10</b>
General safety .....	4	Installation .....	10
Electrical safety .....	4	Future transportation .....	13
Product safety .....	5	<b>4 Operating the hood</b>	<b>14</b>
Intended use .....	6	<b>5 Maintenance and care</b>	<b>16</b>
Children's safety .....	6	General information .....	16
Disposing of the old product .....	7	Replacing the lamp .....	17
Package information .....	7	<b>6 Troubleshooting</b>	<b>18</b>
<b>2 General information</b>	<b>8</b>	<b>7 Guarantee Details</b>	<b>19</b>
Overview .....	8		
Scope of delivery .....	9		
Technical specifications .....	9		

## **1 Important instructions and warnings for safety and environment**

This section contains safety instructions that will help protect from risk of personal injury or property damage. Failure to follow these instructions shall void any warranty.

### **General safety**

- Risk of Toxicating! While the appliance is operating, air in the entire house is drawn in. If adequate ventilation is not provided, waste and toxic gasses which are released as a result of burning will be drawn back into the house through chimney draught. Do not operate the appliance together with sources that may emit toxic gasses and create air draught (wood, gas, oil, and coal stoves, water heaters, kettles, etc.).
  - Always have the authorized persons check the adequacy of ventilation and chimney draught in your building.
  - The appliance is not intended for use by persons (including children) with reduced physical, sensory or mental capabilities, or lack of experience and knowledge, unless they have been given supervised or instruction concerning use of the appliance by a responsible person for their safety.
- Young children should be supervised to ensure that they do not play with the appliance. Cleaning and user maintenance procedures should not be performed by the children unless they are under supervision.
- Always have the installation and repair procedures performed by Authorised Service Agent. Manufacturer shall not be held responsible for damages arising from procedures carried out by unauthorised persons.
  - Do not operate the appliance if it is defective or has any visible damage.
  - Make sure that the appliance is switched off after every use.
  - Appliance must be installed by a qualified person in accordance with the regulations in force. Otherwise, the warranty shall become void.

### **Electrical safety**

- To get your product ready for use, firstly you must have installation place and electric wiring prepared. Later, you may call Authorised Service nearest to you.

- If it has a failure, the product should not be operated without being repaired by the Authorised Service Agent. There is the risk of electric shock!
  - Never connect the hood before installation is completed.
  - Product must be disconnected from the mains during installation, maintenance, cleaning and repair procedures.
  - If the supply cord is damaged, it must be replaced by the manufacturer or its service agent or a similarly qualified person in order to avoid a hazard.
  - Never connect power cable near to the hobs. If melted down, cable may lead to fire.
  - Any work on electrical equipment and systems may only be carried out by authorised and qualified persons.
  - In case of any damage, switch off the product and disconnect it from the mains. To do this, turn off the fuse at home.
  - Make sure that fuse current is compatible with the product.
  - Never wash down the product with water! There is the risk of electric shock!
- Product safety**
- The height between the lower surface of the hood and upper surface of the hob should not be less than 650 mm.
  - Never touch the hood's lamp after they operated for a long time. Hot lamps may burn your hands.
  - Never operate the product without oil filter. Never remove filters when the product is in use.
  - Avoid big flames beneath the product. Otherwise, particles on oil filter may flame up and cause fire.
  - Turn on the hobs after placing pans or pots on. Otherwise, rising temperature may deform certain parts of your product.
  - Turn off the hobs before taking away pans or pots.
  - Avoid inflammable materials under the hood.
  - Do not expose the product to open flames beneath it. It can cause oils accumulated in the filter to catch fire. Do not operate the product without filter.
  - Never leave the cooker unattended when frying foods, the oil may flame up and boiled oil may cause fire. Thus, be careful about cloths and curtains.
  - If the hood is not periodically and properly cleaned, this may cause burning risk on your hood.
  - For refreshing the kitchen's air from cooking smells and steams, please turn on your hood for 15

minutes more after cooking or frying has ended.

- There shall be adequate ventilation of the room when the range hood is used at the same time as appliances burning gas or other fuels. (Not applicable to appliances that only discharge the air back into the room)
- In the environment where the hood is being used, the exhaust of fuel oil or gas devices such as room heater must be absolutely insulated or device must be hermetical type.
- If there is a fuel oil or gas device in the environment, the room must be ventilated sufficiently.
- When a non-electrically operated device is concurrently used in the environment together with the hood, the negative pressure in the room must be maximum 0.4 mbar to avoid the hood's returning other device's exhaust into the room.
- Never connect the hood to the chimneys used for heaters, waste gas or with rising flames. Observe authorities' regulations on the draining of output air.
- When connecting to the chimney, use 120-mm diameter pipes. Pipe connection must be as short as possible with fewer bends.
- Do not hang easily flammable and combustible materials on hood handles.

- Our company shall never be responsible for the problems arising from the use against the warnings above.
- There is a risk of fire if cleaning is not carried out in accordance with the instructions.
- Do not flambé under the range hood.
- Caution: Accessible parts may become hot when used with a cooking appliance.
- You are recommended to clean your filter once a month in normal use.

### **Intended use**

This product is designed for domestic use. Commercial use is not admissible. The manufacturer shall not be liable for any damage caused by improper use or handling.

### **Children's safety**

- Keep children away from the product when it is operating and do not allow them to play with the product.
- Packaging materials are dangerous to children. Keep the packaging materials in a place where children cannot reach and sort and discard them in accordance with the waste disposal directives.
- Electrical products are dangerous to children. Keep children away from the product when it is operating and do not allow them to play with the product.

## Disposing of the old product

### Compliance with the WEEE Directive and Disposing of the Waste Product:



This product complies with EU WEEE Directive (2012/19/EU). This product bears a classification symbol for waste electrical and electronic equipment (WEEE).

This product has been manufactured with high quality parts and materials which can be reused and are suitable for recycling. Do not dispose of the waste product with normal domestic and other wastes at the end of its service life. Take it to the collection center for the recycling of electrical and electronic equipment. Please consult your local authorities to learn about these collection centers.

### Compliance with RoHS Directive:

The product you have purchased complies with EU RoHS Directive (2011/65/EU). It does not contain harmful and prohibited materials specified in the Directive.

### Package information

- Packaging materials of the product are manufactured from recyclable materials in accordance with our National Environment Regulations. Do not dispose of the packaging materials together with the domestic or other wastes. Take them to the packaging material collection points designated by the local authorities.

## 2 General information

### Overview

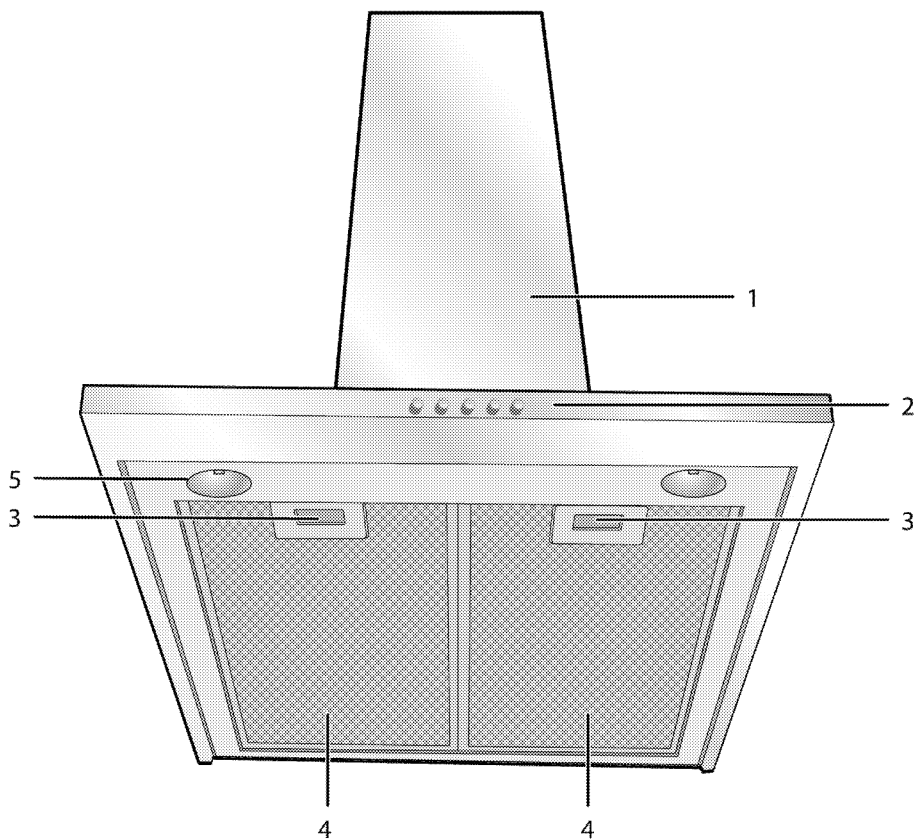

- 1 Hood body
- 2 Control panel
- 3 Aluminum filter lock

- 4 Aluminum filter
- 5 Lamp



## Scope of delivery



Accessories supplied can vary depending on the appliance model. Not every accessory described in the user manual may exist on your appliance.

1. User manual
2. Wall connector

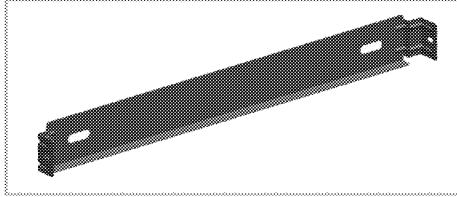

3. Air directing component

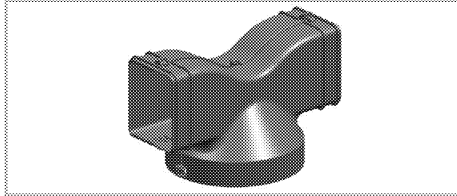

4. Chimney connection adapter

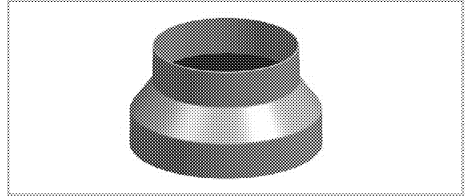

5. Valves to prevent reverse air flow

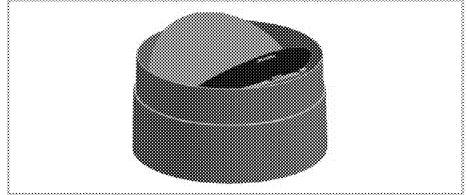

## Technical specifications

External dimensions (height/width/depth)	min. 760 mm max. 915 mm/598 mm/490 mm
Voltage/frequency	220-240 V ; 50 Hz
Control	3 level + 1 Booster
Suction power	680 m <sup>3</sup> /h
Total power consumption	max. 100 W
Fuse	3 A
Air outlet pipe diameter	120-150 mm



Technical specifications may be changed without prior notice to improve the quality of the product.



Figures in this manual are schematic and may not exactly match the product.



Values stated on the markings of the product or in other printed documents supplied with the product are obtained under laboratory conditions as per relevant standards. Depending on operational and environmental conditions of the product, these values may vary.

### 3 Installation

Refer to the nearest Authorised Service Agent for installation of the product. Make sure that the electric installations are in place before calling the Authorised Service Agent to have the product ready for operation. If not, call a qualified electrician and fitter to have the required arrangements made.



Preparation of location and electrical installation for the product is under installer's responsibility.



#### DANGER:

The product must be installed in accordance with all local electrical regulations.



#### DANGER:

Prior to installation, visually check if the product has any defects on it. If so, do not have it installed. Damaged products cause risks for your safety.



#### DANGER:

Warning: Failure to install the screws or fixing device in accordance with the instructions may result in electrical hazards.

### Installation

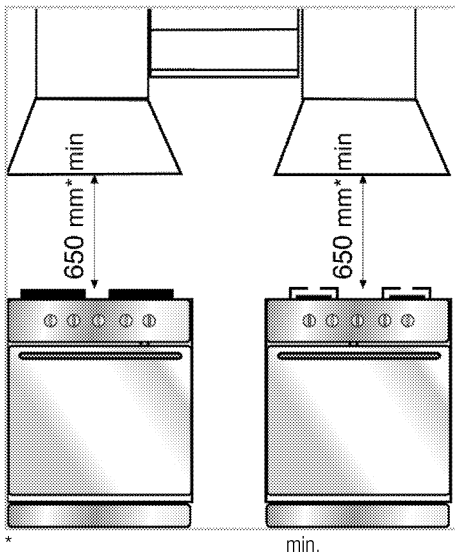

There should be a minimum clearance of 650 mm between the top surface of the hob and the bottom surface of the hood.

The air to be extracted via the hood should not be connected to a chimney that is used by other

appliances that use gas or other fuels. (It does not apply to devices that only blow the air back into the room)

The regulations on air exhaust should be followed.

#### Electrical connection

Manufactured with 2-track power cable, this device must be connected to the mains by an electrical switch with at least 3mm clearance between bipolar contact leads. Have the electrical connections done by a qualified electrician.

- Install your appliance so that you can reach the power connection (plug, outlet) easily after installation.

#### Installing the hood



Measurements are in mm.

The following provides necessary information to prepare the location for hood installation.

The hood must be installed above the central axis of the cooking appliance. There should be a minimum clearance of 650 mm between the top surface of the hob and the bottom surface of the hood. Please apply the following steps for the hood's installation.

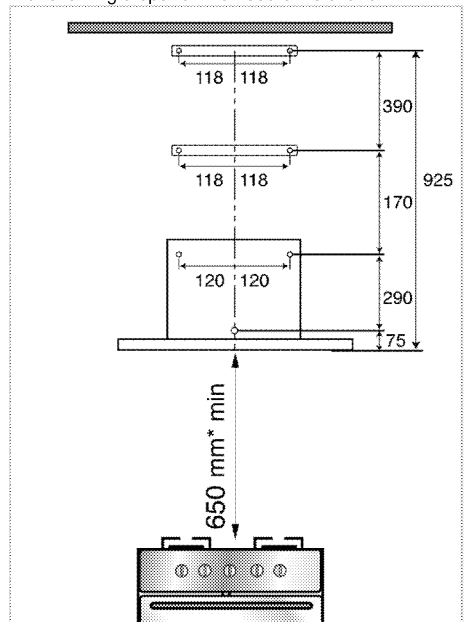

1. Centering the cooking appliance, draw an axis line that has the same height as that of the figure above. Then, taking this axis line as reference and

according to the measurements above, drill 7 holes whose sizes are in compliance with the fittings provided with the product.

2. Insert the plastic plugs which are given with the packaging into these holes. Check if chimney connectors correspond to those holes or not.

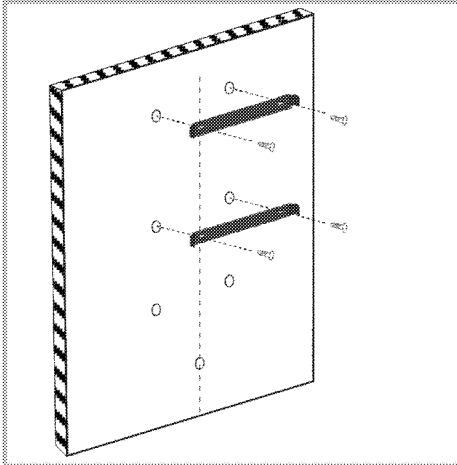

3. As shown in the figure above, fix the wall fittings to their corresponding holes using the two fixing screws provided with the accessories.
4. For electronic models, fix the electronic mainboard into its housing with 4 screws as shown in the figure below.

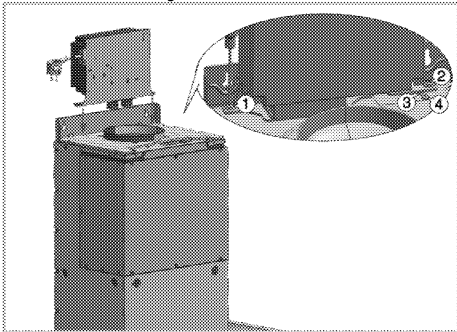

5. Fix the hood to the wall by centering it through the A holes. Remove the aluminum filters of the hood. On the inside, fix the back plate of the hood through the B hole using a screw as shown in the figure below. Make sure that the hood is parallel to the counter when fixing.

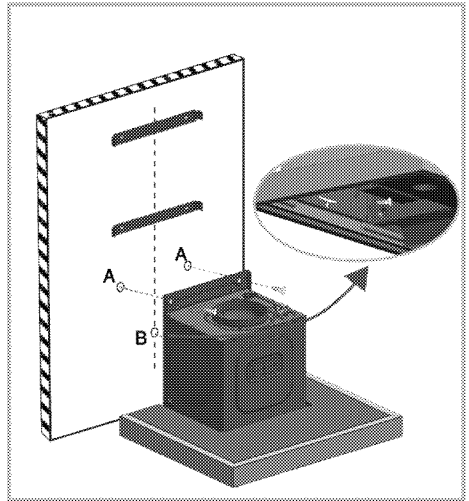

6. As shown in the figure below, place the cover (C) that prevents reversed air flow- to the chimney outlet.

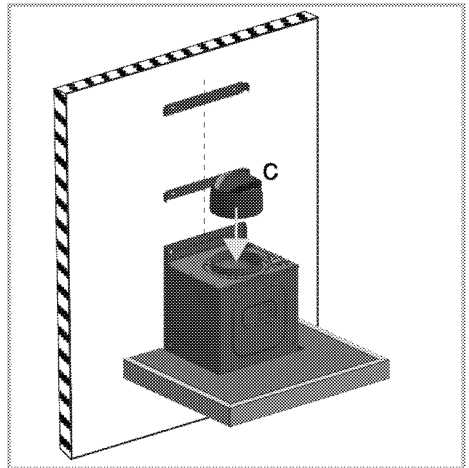

**7. For chimney connection usage:**

In chimney connection installation, the absorbed air will pass through the aluminium filters and will be expelled to the outside through the connection pipe.

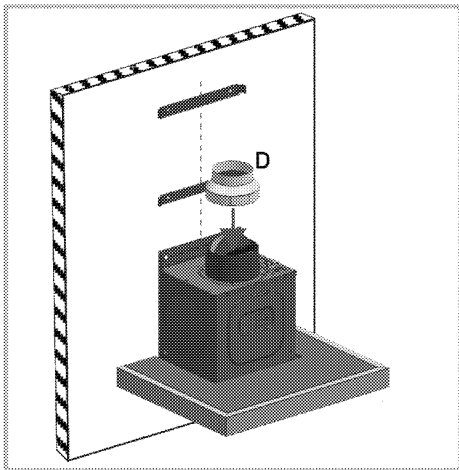

When this connection position is used, chimney connection adapter D is placed on part C as shown in the figure above.

**i** D chimney connection adaptor will only be used when the chimney connection pipe's diameter is 120mm. If your chimney connection pipe's diameter is 150mm, you will not need to use chimney connection adaptor D and therefore you will need to connect one end of the chimney connection pipe E directly onto cover C.

8. Connect one end of the chimney connection pipe E to the chimney connection adapter and place the other end to the chimney. You can obtain the chimney connection pipe E from the authorized service or from the market (from any DIY store-for Ireland, United Kingdom).

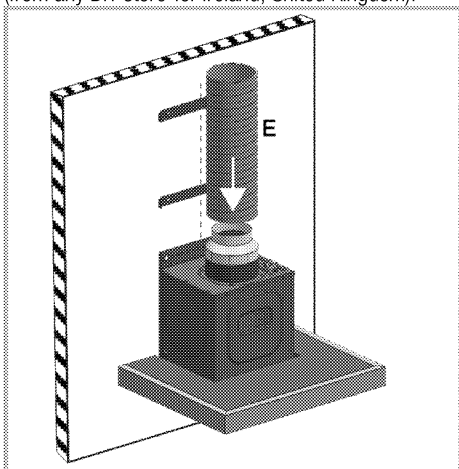

You should make sure that the chimney connection pipes used are made of fireproof plastic material. When using flexible connection pipe, it should be considered that sharp corners and sudden contractions will have a negative impact on air suction. The hood must never be connected to a chimney to which another device was already connected.

**i** Connection pipe should not be larger than 120 mm; otherwise, proper chimney connection will be prevented.

### 9. Internal circulation (Use with carbon filter)

In the position of internal circulation, the air absorbed from the environment will go through aluminium filters and carbon filters, where the smell is eliminated, and pass through air directing component, it is finally sent back to the environment through the ventilation grills on the side of the chimney piece.

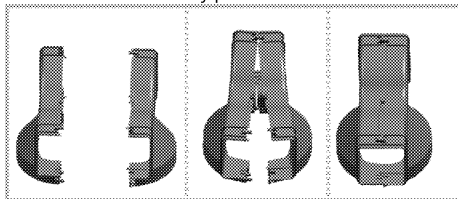

Assemble the air directing component, that is provided as two separate parts, as shown in the figure.

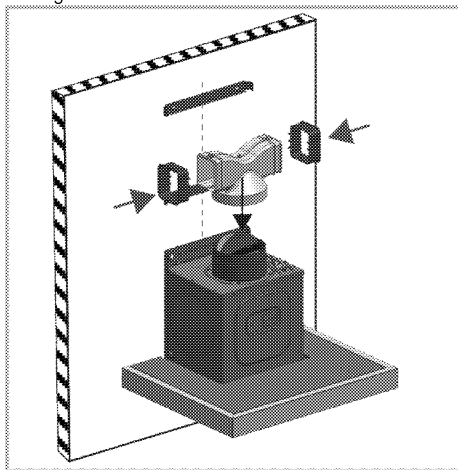

Fix the air directing component's extension parts onto the sides as shown in the figure. As shown in the figure above, fix the air directing component onto the cover (C) that prevents reversed air flow.

10. Remove aluminum filters as shown below.

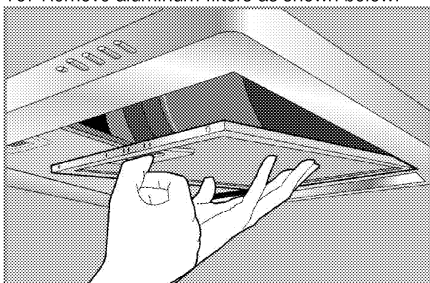

11. Install the carbon filter as per the following figure.

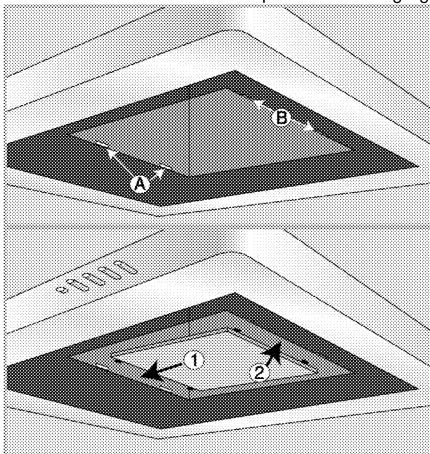

Re-install aluminum filters.

## 12. Installation of chimney

To install the upper chimney, place its upper corners onto the upper wall connector and use the screws to fix the chimney to the wall connector as shown in the figure below.

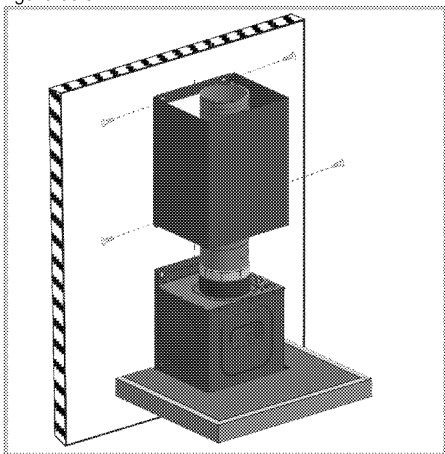

To install lower chimney, stretch the chimney by pulling slightly from both sides and secure it onto upper chimney's slots as shown in the figure above.

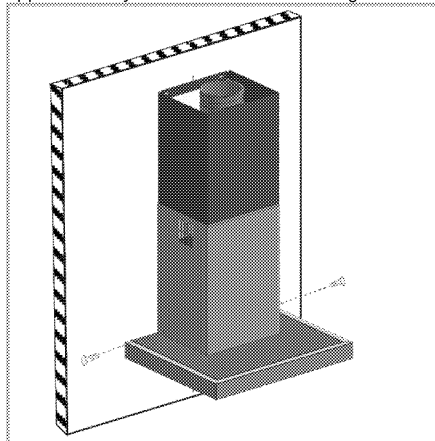

Fix it to the hood through the two holes on the lower corners of the lower chimney.

**You may use the hood in two ways:**

### 1-Chimney-connected use

The steam is expelled via chimney pipe which is secured to the connection ring on the hood. Diameter of chimney pipe should be equal to connection ring. To allow the air easily going out of the room in horizontal arrangements, the pipe should be slightly tilted upwards (approximately 10°).



If the carbon filter is installed on your hood, remove it when using the hood with the chimney.

### 2- Use with no chimney connection

Air is filtered through carbon filter and returned to the room. Carbon filter is used when there is no chimney in the house or when it is impossible to install a chimney pipe.

- Install the carbon filter as described in the installation section.

### Future transportation

- Keep the product's original carton and transport the product in it. Follow the instructions on the carton. If you do not have the original carton, pack the product in bubble wrap or thick cardboard and tape it securely.



Do not place any objects onto the product and move it in upright position.



Check the general appearance of your product for any damages that might have occurred during transportation.



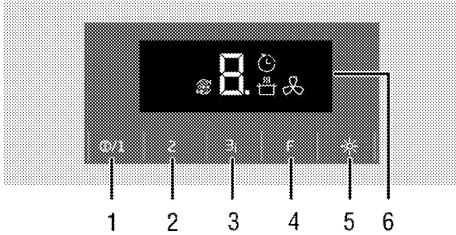

## 4 Operating the hood

Hood is equipped with a motor with various speed settings.

For a better performance, we advise you to use low speeds in normal conditions, and high speeds when smell and vapors are intensified.



- 1 On/off button / Speed1
- 2 Speed2
- 3 Speed3 / Booster
- 4 Function key
- 5 Lamp key
- 6 Display

-  Auto off symbol
-  Booster symbol
-  Filter full warning symbol
-  Air filter mode symbol

### Operating the hood

1. To turn on the hood, touch the on/off key.
  2. To change the speed, touch Speed2 and Speed 3 keys.
- » Speed level of the hood shall be displayed.



Do not touch both keys simultaneously. If touched, higher speed will be activated.



Appliance operates for a maximum of 6 hours when no key is touched while it is operated.

### Auto off mode

1. Touch the function key when the appliance is operated at a certain speed. Auto off mode will be activated and  symbol is displayed.
2. Appliance shall be turned off automatically after operating for 20 minutes at the set level.



Auto off mode is canceled when any level key other than the lamp key is pressed.

### Activating intense ventilation mode (Booster)

Touch the speed3 key for more than two seconds. Intense ventilation mode will be activated and P and  symbol shall be displayed, and the appliance will be active for maximum 10 minutes. After 10 minutes, it will continue to operate in Speed 3 position. During intense ventilation, if any of the speed keys is touched then the operation will continue in that speed level.

### Turning off the hood

1. Touch on the Off key when the hood is operating in a certain speed.
- » When the hood is being turned off, "0" is flashed on the display for 8 seconds while motor is being stopped. This is not an error.

### Operating the lamp

1. Touch the lamp key to turn on the lamp.

### Turning off the lamp

1. Touch the lamp key again to turn off the lamp.



Off key does not turn off the lamp, it only stops operation of the hood.

### Air filter mode

1. Touch the function key when the appliance is not operated at any speed.
- » Air filter mode will be activated and C and  symbol is displayed.
2. Air filter mode will operate for 10 minutes at speed 1 level and then stops for 50 minutes within 1 hour. If the air filter mod will not turned off, it will continue to operate for 10 minutes and stops 50 minutes for each each hour during 24 hours.



You can utilize air filter mode to remove odor found in-house in long term using low speed.

### Turning off the air filter mode

1. Turn off the air filtering mode by touching any speed key or touching the off key while the air filtering mode is active.



While the air filter mode is active, when you turn on and off the appliance at any speed level, air filter mode shall not be remembered.



While the air filter mode is active, the program will be canceled if there is a blackout.

### **Filter full warning**

After every 100 hours operation, F symbol and the set level flashes in turn on the display. Also,  symbol appears on display. Clean your filter. Filter full warning will not reset automatically after cleaning.

Filter full warning may be reset by pressing function and speed3 buttons for 3 seconds simultaneously.



When the hood gave filter full warning, the warning will not be reset if there is a power outage.

## 5 Maintenance and care

### General information

Service life of the product will extend and frequent problems will decrease if the product is cleaned at regular intervals.



#### DANGER:

Disconnect the product from mains supply before starting maintenance and cleaning works.

There is the risk of electric shock!

- Clean the product thoroughly after each use. In this way it will be possible to remove cooking residues more easily, thus avoiding these from burning the next time the appliance is used.
- No special cleaning agents are required for cleaning the product. Use warm water with washing liquid, a soft cloth or sponge to clean the product and wipe it with a dry cloth.
- Do not use cleaning agents that contain acid or chloride to clean the stainless or inox surfaces and the handle. Use a soft cloth with a liquid detergent (not abrasive) to wipe those parts clean, paying attention to sweep in one direction.



The surface might get damaged by some detergents or cleaning materials.

Do not use aggressive detergents, cleaning powders/creams or any sharp objects during cleaning.



Do not use steam cleaners for cleaning.

### Aluminum filter

This filter captures oil particles in the air. **You are recommended to clean your filter once a month in normal use.** Please firstly remove aluminum filters for this process. Wash the filters in liquid-detergent water and install them after drying. Aluminum filters might change colour in time due to washing. This is normal and you don't need to replace the filter.

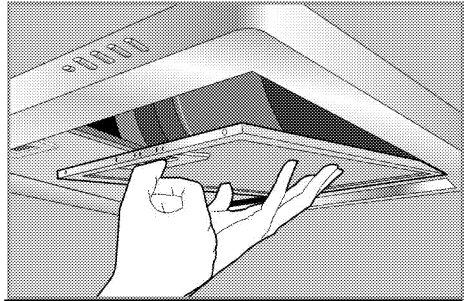

You can also wash aluminum filters in dishwasher.

### Removing aluminum filters

1. Push aluminum filter lock forward.
2. Slightly lower the filter and pull forth. Otherwise, you may bend the filter.
3. After washing, reverse the steps above to re-install the aluminum filter.

### Carbon filter (Use without chimney)



Carbon filter should never be washed.

It should be replaced once every 4 months in normal use. You may obtain carbon filters from the Authorised Service.

### Fitting the carbon filter

1. Remove aluminum filters
2. After the filters are removed, insert the side with flexible-short tips of the carbon filter which provided with the product, into the slot A of the hood in direction 1.

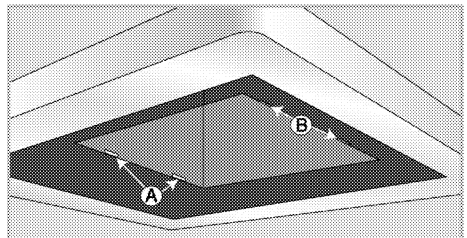



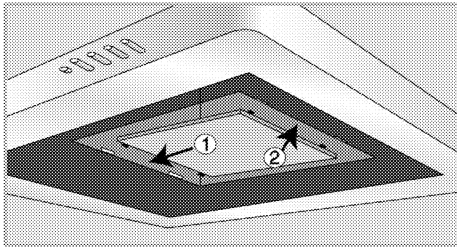

3. Insert the long-hard tips found on the other side of the carbon filter into the slot B in direction 2.
4. Ensure that both ends of the carbon filter are secured firmly.

### Replacing the lamp



**DANGER:**

Before replacing the lamp, make sure that the product is disconnected from mains in order to avoid the risk of an electrical shock. If hot, let the lamp cool down.  
Hot surfaces may cause burns!



For the specifications of the lamp, see *Technical specifications, page 9*. Oven lamps can be obtained from Authorised Service Agents.



Position of lamp might vary from the figure.



The lamp used in this appliance is not suitable for household room illumination. The intended purpose of this lamp is to assist the user to see foodstuffs.

1. Remove the lamp pressing it towards its seat in clockwise direction (1) and then remove turning it in counterclockwise direction (2).

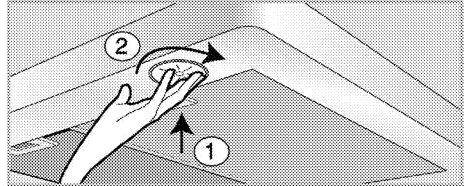

2. Insert the new lamp turning it in clockwise direction.
3. A "click" will be heard when the lamp is secured in its place.

## 6 Troubleshooting

### Product does not operate.

- The mains fuse is defective or has tripped. >>> *Check fuses in the fuse box. If necessary, replace or reset them.*
- Product is not plugged into the socket. >>> *Check the plug connection.*
- Speed button might not be set. >>> *Press the required speed button.*
- Power is cut. >>> *Check if there is power. Check the fuses in the fuse box. If necessary, replace or reset the fuses.*

### Hood light does not work.

- Hood lamp is defective. >>> *Replace the hood lamp.*
- Power is cut. >>> *Check if there is power. Check the fuses in the fuse box. If necessary, replace or reset the fuses.*



Consult the Authorised Service Agent or the dealer where you have purchased the product if you cannot remedy the trouble although you have implemented the instructions in this section. Never attempt to repair a defective product yourself.

## **7 Guarantee Details**

Your new Beko product is guaranteed against faulty materials, defective components or manufacturing defects. The guarantee starts from the date of original purchase of the product for a period of twelve (12) months unless Beko plc (the "Manufacturer") agrees to extend the guarantee for the product in writing. If you have any questions about the guarantee on your product (including how long it is valid), please contact your retailer or our Call Centre on 0333 207 9710.

This guarantee does not in any way diminish or affect your statutory rights in connection with the product. This guarantee is in addition to your statutory rights as a consumer. If you have any questions about these rights, please contact the retailer from which you purchased the product. In certain circumstances, it is possible that your statutory rights may offer additional or higher levels of protection than those offered under the terms of this guarantee.

### **What is covered by this guarantee?**

- Repairs to the product required as a result of faulty materials, defective components or manufacturing defects.
- Functional replacement parts to repair a product.
- The costs of a Beko Approved Engineer to carry out the repair.

### **What is not covered?**

- Transit and delivery damage.
- Cabinet or appearance parts, including but not limited to control knobs, flaps and handles.
- Accessories and/or consumable items including but not limited to ice trays, scrapers, cutlery baskets, filters and light bulbs.
- Repairs necessary as a direct or indirect result of:
  - Accidental damage, misuse or abuse of a product.
  - An attempted repair of a product by anyone other than a Beko authorised repairer.
  - Installation or use of a product where such installation or use fails to meet the requirements contained in this guarantee or the User Instructions Booklet.
- Repairs to a product operated at any time on commercial or non-residential household premises (unless we have previously agreed to the installation environment).

This guarantee is limited to the cost of repairing the product. To the extent permitted by law, the Manufacturer does not accept and will not be held liable for any financial loss incurred in connection with the failure of any product to operate in accordance with the expected standards. Such financial loss includes but is not limited to loss arising from:

- Time taken off work.
- Damaged food, clothing or other items.
- Meals taken at restaurants or from takeaways.
- General compensation for inconvenience.

### **Important Notes**

- Your product is designed and built for domestic household use only.
- The guarantee will automatically be void if the product is installed or is used in commercial or non-residential domestic household premises, unless we have previously agreed to the installation environment.
- The product must be correctly installed, located and operated in accordance with the instructions contained in the User Instructions Booklet provided with your product.
- Professional installation by a qualified Electrical Domestic Appliance Installer is recommended for all Washing Machines, Dishwashers and Electric Cookers (as incorrect installation may result in you having to pay for the cost of repairing the product).
- Gas Cookers must be professionally installed by a Gas Safe (or Gas Networks Ireland for Republic of Ireland) registered gas installer.

- This guarantee is given in respect of products purchased and used within the United Kingdom and the Republic of Ireland.
- This guarantee is effective from the initial date of purchase of a new product from an authorised retailer and will be void if the product is resold.
- This guarantee does not apply to graded sales (where the product is purchased as a “second”).
- Possession of a copy of these terms and conditions does not necessarily mean that a product has the benefit of this guarantee. If you have any questions, please call our Call Centre on the number set out above.
- The Manufacturer reserves the right to terminate the guarantee if its staff or representatives are subjected to physical or verbal abuse in the course of carrying out their duties.
- Optional extras, where available (i.e. extendable feet) are supplied on a chargeable basis only.

### **Does Beko offer replacements?**

This is a repair-only guarantee. On occasion, the Manufacturer may at its sole discretion, replace your product with a new product instead of carrying out a repair. Where a replacement is offered, this would normally be an identical model but when this is not possible, a model of similar specification will be provided. The Manufacturer will cover the costs and arrange for the delivery of the new product and for the return of the old product. Any costs related to disconnecting the faulty product and installing the replacement product will not be borne by the Manufacturer unless previously agreed to in writing. The original guarantee will continue to apply to the replacement product; the new product will not come with a new guarantee.

### **When will the repair take place?**

Our Engineers work Monday to Friday 9.00am to 5.00pm. Appointments outside these hours may be possible at the sole discretion of the Manufacturer but cannot be guaranteed. Whilst our Engineers will endeavour to minimize inconvenience and to meet requests for specific timed appointments, this cannot be guaranteed. We will not be liable for delays or if it is unable to carry out a repair because a convenient appointment cannot be arranged.

### **Will there be any charge for the repairs?**

It is your responsibility to provide evidence to the Engineer that your product is covered by this guarantee with a proof of purchase. The Manufacturer reserves the right to charge for the reasonable cost of any service call if:

- You cannot provide evidence that your product is covered by this guarantee.
- Where a service call has been made and the engineer finds that there is no fault with your product.
- That your product has not been installed or operated in accordance with the User Instructions Booklet.
- That the fault was caused by something other than faulty materials, defective components or manufacturing defects.
- For missed appointments.

Payment of these costs are due immediately upon the Engineer providing you with an invoice. The Manufacturer reserves the right to terminate the guarantee if you fail to pay the costs for the service call in a timely manner.

If you are a resident of the United Kingdom, this guarantee will be governed by English law and subject to the English Courts, save where you live in another part of the United Kingdom, in which case the law and courts of that location will apply.

If you are resident in the Republic of Ireland, this guarantee will be governed by Irish law and the Irish courts will have jurisdiction.

## HOW TO OBTAIN SERVICE

Please keep your purchase receipt or other proof of purchase in a safe place; you will need to have it should the product require attention under guarantee.

It will be useful if you complete the details below, as it will help us assist you when requesting service (the model number is printed on the Instruction Booklet and the serial number is printed on the Rating Label affixed to the appliance). Recording of these details alone will not count as proof of purchase. A valid proof of purchase is required for under guarantee service.

The area around the product must be easily accessible to the Engineer without the need for cabinets or furniture being removed.

It is your responsibility to ensure our Engineers have a clean and safe environment to carry out any repairs.

.....  
Model No:

Serial No:

Retailer:

Date of purchase:  
.....

**For service under guarantee simply telephone the appropriate number below:**

**UK Mainland & Northern Ireland:** 0333 207 9710 or [customerservice@support.Beko.co.uk](mailto:customerservice@support.Beko.co.uk)

**Republic of Ireland:** 01 862 3411 or [customerservice@support.Beko.ie](mailto:customerservice@support.Beko.ie)

**Register your appliance:** For UK registrations visit [beko.co.uk/register](http://beko.co.uk/register) and for the Republic of Ireland [beko.ie/register](http://beko.ie/register).

Before requesting service please check the troubleshooting guide in the Operating Instructions as a charge may be levied where no fault is found even though your product may still be under guarantee.

**Service once the manufacturers guarantee has expired**

If you have purchased an extended guarantee please refer to the instructions contained within the extended guarantee agreement document, otherwise please call the appropriate number above where service can be obtained at a charge.

Should you experience any difficulty in obtaining service contact the Beko Customer Helpline on Tel: 0333 207 9710 or e-mail: [CustomerService@support.beko.co.uk](mailto:CustomerService@support.beko.co.uk)  
.....

This guarantee is provided by Beko plc. Beko House, 1 Greenhill Crescent, Watford, Herts, WD18 8QU. Beko plc is registered in England and Wales with company registration number 02415578.





