

**Built in Hob**

**Model  
HIC 64102**



Dear customer

Congratulations on your choice of a Beko quality appliance which has been designed to give you lasting service.

The appliance must be installed by a qualified electrician in accordance with current regulations and used in a well ventilated space.

Please read these instructions thoroughly before installing or using - and keep for handy reference. Make sure you understand the controls prior to using your appliance. This cooker must only be used for its intended purpose, ie the cooking of food in the home. Failure to observe these instructions may invalidate your right to free service during the guarantee period.

If you have any questions, or if you are not sure about any information contained in this booklet please contact us - details are on the back cover.

Beko Customer Service

---

## safety symbols

The use of any electrical appliance in particular (which use high temperatures) require the following of basic common sense safety rules.

There is a danger of injury to the person and of damage to the appliance, the kitchen and your home.

These are itemised in the first section 'Safety in the home'. Where accidents are most common, we repeat these warnings in the main text using the following symbols:

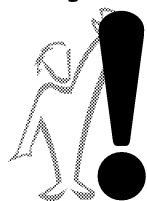

**Where you, other people, toddlers and children are at risk**



**Where there is a danger of damage to the appliance, utensils, surrounding areas and property**

Please note them for your own safety.

# contents

---



## **Introduction**

Welcome/Safety symbols	2
Safety in the home	4

## **Installation**

Know your appliance/ specification	7
Electrical connection	8
Location	9
Ventilation	11
Installation	11

## **For the very first time**

Preparation and burning off	11
-----------------------------	----

## **Operating**

Operating the hob	12
Saucepan types/deep fat frying	13

## **Cooker care**

Care & cleaning	14
Trouble shooting	15
Future transportation	15
Guarantee / Service	16

## Look after yourself, family and friends

- The appliance is not intended for use by young children or infirm persons without supervision.

Young children should be supervised to ensure that they do not play with the appliance.

**WARNING: To avoid risk of electric shock, immediately switch off the appliance from the mains to avoid the possibility of an electric shock if a crack is detected on the ceramic glass surface caused by mechanical impact.**

**You should contact our customer service department.**

- It is therefore advisable to have the glass insured against breakage in the household and personal effects insurance.
- If the appliance is to be installed above a cupboard, than a barrier is to be installed. Please refer to installation instructions.
- During use surfaces get hot. Don't touch hot surfaces during use.
- Don't store items above the appliance that children may try to reach.
- Close supervision while cooking is essential at all times.
- When deep-frying, the appliance should be supervised as overheated fats and oils can catch fire easily. Never attempt to extinguish burning oil or fat with water (risk of explosion!). Smother a fire with wet towels and keep doors and windows closed!
- Ensure handles of pans can not accidentally be caught or knocked and do not get heated by adjacent heating zones.
- Check all controls on the appliance are switched off after use.

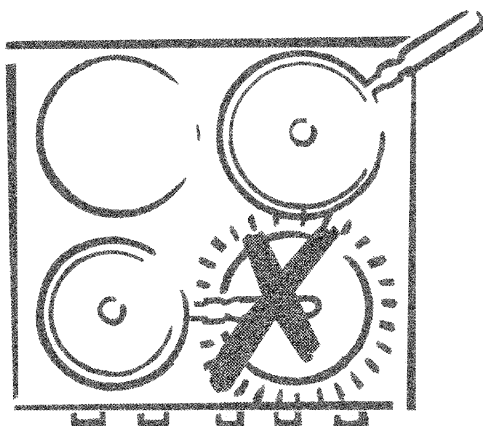

## Look after your appliance and home

- Clean your appliance regularly, ideally after each use. Always turn off the mains electricity supply and allow the appliance to cool first.
- Spillage should be dealt with as soon as it occurs, taking due care as the appliance surface may be hot. Any spillage left on the surface after cooking should be cleaned off before the appliance is switched on again to prevent baking on.
- Don't use biological washing powder or bleach products, harsh abrasives or chemical cleaners for cleaning.
- Ensure that no flammable materials are adjacent to the appliance as the sides become hot during use.
- Don't place flammable or plastic items on or near the appliance, and never place wet cloths etc. on the appliance to dry.
- Don't leave an appliance on for long periods when not covered by a pan.
- Don't use water to extinguish oil or fat fires.
- Don't heat up unopened food containers as pressure can build up causing the container to burst.
- Don't use round-bottomed traditional woks. Use flat-bottomed types.
- Do not use a steam cleaner to clean this appliance.
- Don't stare at halogen heating zones.
- The surfaces of the stainless steel model appliances which are close to the burners may change colour because of the excessive heat in the course of time.

 **This appliance is not intended for use by persons with reduced physical, sensory or mental capabilities or lack of experience and knowledge unless they have been given supervision or instruction concerning use of the appliance by a person responsible for their safety. Children should be supervised to ensure that they do not play with the appliance.**

## **Important Safety Information**

This appliance is in accordance with the recognized state of the art and the relevant safety provisions. In order to prevent damages and accidents, however, the proper handling of the appliance is a prerequisite. Along with the following information, please take note of further information contained in the text.

- Do not put the appliance into operation if there are visible damages such as cracks or splits in the glass ceramic-plate surface. In this event, please contact our customer service department.
- No alterations or repair attempts, in particular using tools (screwdrivers, etc.) may be undertaken to or on the appliance. Trained professional technicians may only perform repairs, in particular to electrical supply parts. Improper repairs could lead to serious accidents, damages and breakdowns. In the event of a breakdown of the appliance, (before contacting our customer service department), please take note of the information contained under "Warranty terms". Please contact our customer service as needed.

## **How to use:**

- Infirm or mentally handicapped persons and persons who are not able to operate the device properly due to inexperience or lack of knowledge, should use this device under close supervision only. This applies to children, too.
- The glass ceramic hob should not be used for the preparation of food items. In the event that the appliance is misused for another purpose or improperly handled, no liability for possible damages can be assumed.
- Do not use the hob to heat the room.
- As soon as a functional defect is detected or if, e.g. due to extreme mechanical effects, cracks appear in the glass ceramic plate: turn off the appliance and disconnect it from the electrical mains supply (unscrew fuses or respectively deactivate automatic circuit breakers).
- Connection cables of electrical devices should not be exposed to hot cooking zones or the cookware. The electrical insulation may become damaged as a result.

## **This is how you can avoid damages to your glass ceramic hob**

Please observe the following information in order to prevent damages:

- In no event should you pour cold water over the hot burners.
- Do not climb onto the glass ceramic plate.
- A sudden stress could become critical, e.g. during the impact of a saltshaker. Therefore, it is best that you do not store such items above the hob.
- Before each use, you should ensure that the base of the cookware as well as the surfaces of the cooking zones are clean and dry.
- Always lift and do not drag cookware in order to prevent scratching of the glass ceramic plate and wear and tear to the décor.
- Avoid peeling or chopping vegetables upon the hob surface. Grains of sand can scratch the glass ceramic plate.
- Do not use the hob as a storage surface; in particular, do not lay any flammable materials, cartons or plastic packages upon it. Objects made of pewter, zinc or aluminium (also aluminium foils or an empty espresso maker) could melt on hot cooking zones and cause damage.
- Take care that no sugar-containing foods or juices come into contact with hot cooking zones. The surface of the glass ceramic plate could be strained as a result. Remove overflows immediately with caution even while still in a hot state.
- Do not place hot pots or pans on the frame of the burner.
- When cleaning, care should be taken that no water penetrates the appliance, as penetrating water could cause damage. Therefore, you should only use moist cloths. Never squirt water onto the appliance and refrain from using steam cleaners.

## **Disposal of Waste**

- Please separate the packaging materials for recycling and dispose of it at your Local authority waste collection location. Packaging materials are not toys for children.
- Permanently connected devices (without plug) must be disconnected from the mains supply before removal by a suitable qualified electrician.
- Make the device non-functional before disposal: Cut off mains cable (after unplugging) or any existing loose connection cables on the device.
- Make sure that the appliance is disposed of properly in accordance with local authority instructions.

## **Food hygiene**

- Ensure meat and poultry is thoroughly defrosted before cooking.
- Check food is thoroughly cooked and is piping hot.
- Always refer servicing to a qualified appliance service engineer.

# know your cooker

---

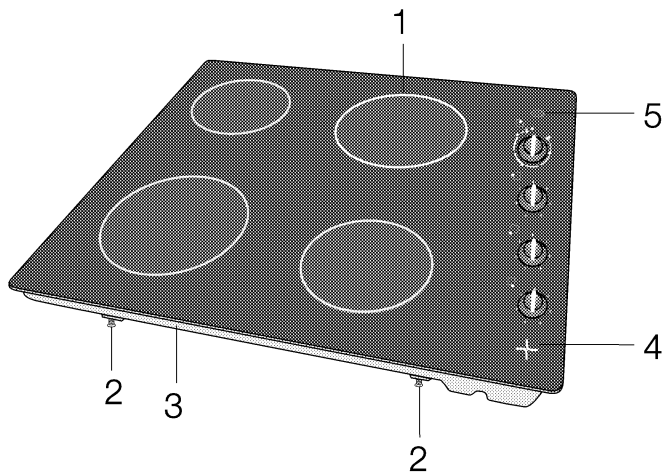

- 1. Ceramic hot plate
- 2. Assembly clamp
- 3. Protection cover
- 4. Hob hot indicator light
- 5. ON/OFF light

## Specification

---

<b>Outer dimensions</b>	
Width	580 mm
Depth	510 mm
Height	71 mm
<b>Dimension installation</b>	
Width	560 mm
Depth	490 mm
Hob wattage-Front left	Ø180-1700 W
Hob wattage-Rear left	Ø140-1200 W
Hob wattage-Rear right	Ø180-1700 W
Hob wattage-Front right	Ø140-1200 W
Total electric power	5800 W
Supply voltage	230V~50Hz



# electrical connection

- Do not connect the appliance to the electricity supply until all packing and transit protectors have been removed. Before your appliance is connected to the mains electricity supply, check to ensure that the voltage and frequency shown on the rating label corresponds with your power supply.
- Before applying for installation have the electrical wiring of your home ready for connection. This product must only be installed by a qualified electrician

## Warning!

### **This appliance must be earthed.**

If the mains connection lead is damaged, it must be replaced by a special connection lead which is available from our customer service department.

**The cable length should be 2 m. max for isolation safety.**

- The mains cable must pass through the cable clamp.
- The mains cable should be routed away from the appliance.

This appliance must be earthed.

Our company shall not held responsible for any damage caused by the utilisation of the hob without an EARTH connection.

The appliance must be connected with the technically equivalent cable of the type H05RRF 3G 2.5

Cable Connections;

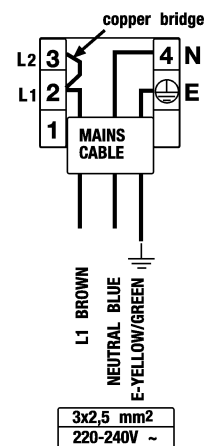

# location

## Assembly of the Built-in Hob

This built-in hob must be installed into a recess in a work surface. Installation and electrical connections should be performed by a suitably qualified technician in accordance with the regulations in force.

The appliance should be connected to a suitable easily accessible double pole control unit with a minimum contact clearance of 3 mm with a minimum rating of 30 amps fitted adjacent too (but not above the hob where it could be affected by heat or steam).

Allow 55 mm clearance from one high side wall to the side corner.

If a cooker is to be fitted underneath the hob, it must be ventilated.

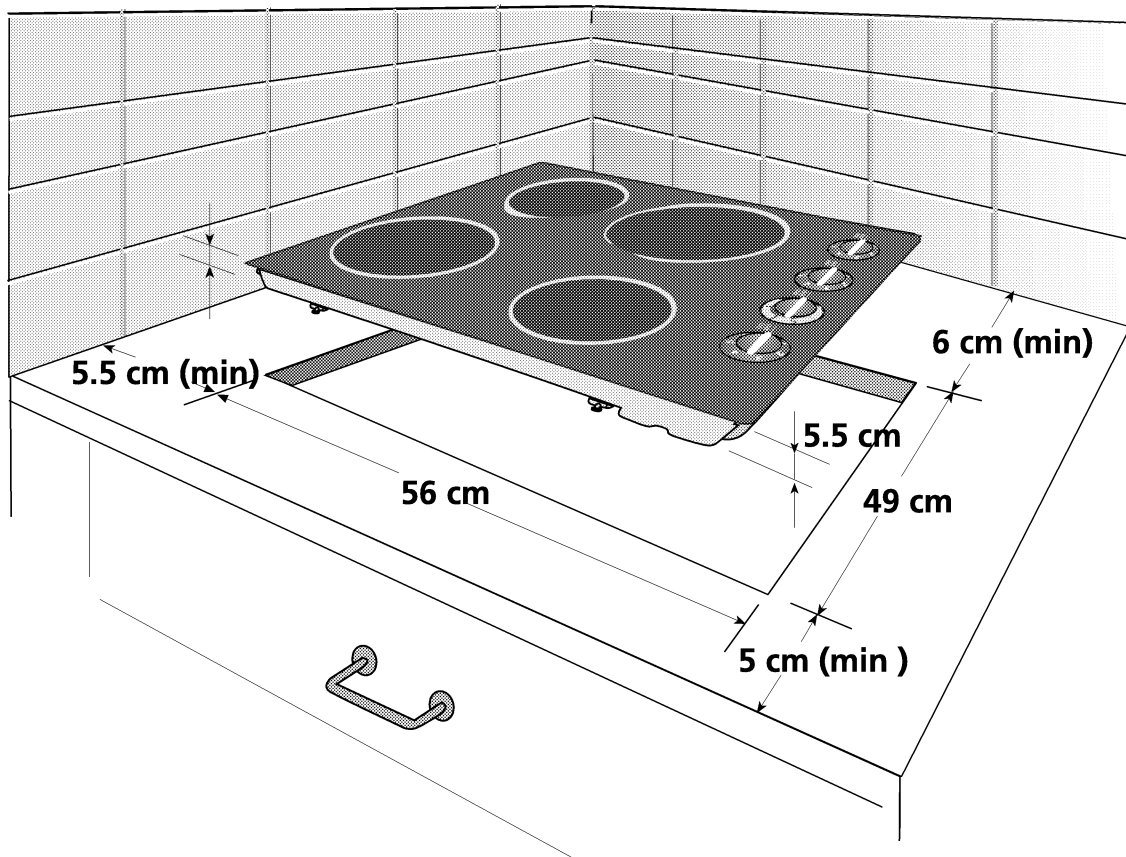

You can install your hob according to the illustrated figure by means of assembly clamps. The assembly clamp may vary dependant on your model.

## Usage of the assembly clamp (if available)

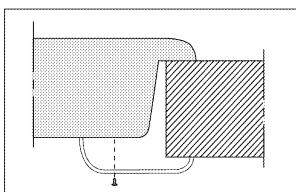

\* For worktop thickness's of less than 20 mm insert a wood spacer between the bracket and the under surface of the worktop.

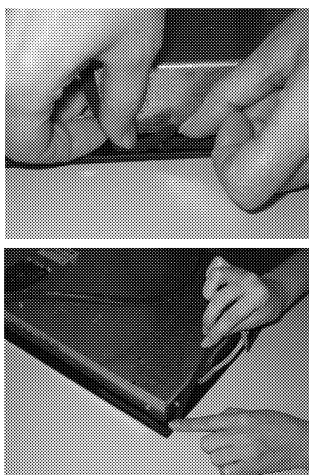

1. Prepare the worktop as shown
2. Remove the sealing gasket from the packaging.
3. The sealing gasket provided in the package must be affixed around the glass frame on the lower surface during the installation of your hob as shown.
4. Position the appliance centrally in the worktop.
5. Tighten the screws of the springs located on the base of the appliance to secure the appliance in position.

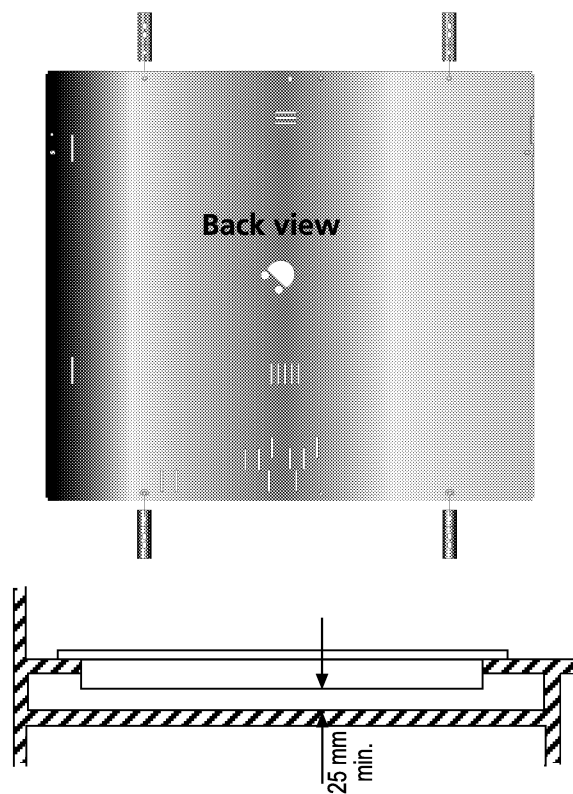

**Attention:** When installing the hob above a cupboard, a dividing shelf as a pictured above must be installed. It installing above an underbench oven this is not required.

If, for example, due to the fitting of the appliance above a drawer, the underside of the appliance is touchable, it must be covered by a wooden plate.

Do not install above a refrigeration appliance, as the performance of this appliance will be severely affected by radiated heat.

# ventilation

---



**Natural ventilation is important for the correct functioning of the appliance and your own safety.**

Prolonged intensive use of the appliance may call for additional ventilation, for example the opening of a window, or the use of permanent fixed mechanical ventilation system, for example, an extractor fan or cooker hood that ventilates to the outside.

# installation

---

## **Unpacking**

All packing materials, protective film and transit protectors must be removed.

**The packaging materials can be dangerous for children. Please store/ dispose of safely.**

# preparation and burning off

---



## **Important for asthmatic sufferers**

Before using for the first time, protective coatings need to be burnt off. Fumes will be emitted but this is quite normal.

**Ensure the room is very well ventilated during the burning off process. Avoid directly inhaling the fumes during this process.**

## **Cleaning**

Before you start using your appliance, clean the appliance as recommended under Care and cleaning on page 14.

# operating the hob

## Control knobs

- 1 Rotate in either direction to switch on and select a heat level. They have 6 fixed positions as described in the table on the right.
- 2 When any one of the heating zones is on, the red indicator light on the control panel is on.
- 3 To switch a heating zone off turn the corresponding knob to 0 (zero).



**Before retiring for the evening it is advisable to check that all the controls have been switched off.**

- A slight buzzing sound can be heard if any of the heating zones comes on. This is normal and not a fault.

## Hob hot indicator lights

Show which hob is operating and/or hot. Indicator lights will remain on whenever the hob is hot. Whenever the temperature of the hob surface falls below 64 degrees °C limit, the indicator light will go off.

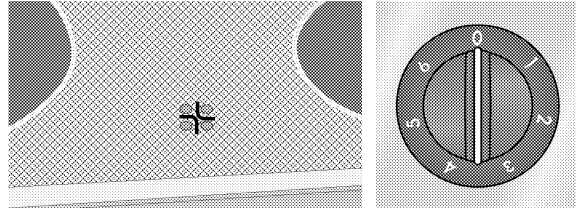

Heat settings		
1	2	3
1	2 - 3	4 - 5 - 6
Warming	Simmering	Cooking-roasting boiling

Diameter 140 mm 1200W  
**Use 6" (15 cm)  
diameter saucepan**

Diameter 180 mm 1700W  
**Use 7" (18 cm)  
diameter saucepan**

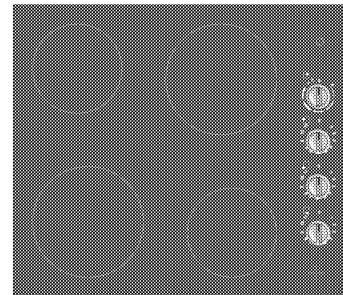

Diameter 180 mm 1700W  
**Use 7" (18 cm)  
diameter saucepan**

Diameter 140 mm 1200W  
**Use 6" (15 cm)  
diameter saucepan**



**Do not touch and keep children away from the heating zones and appliance at all times.**

## Ceramic hob care

The ceramic glass surface is tough in everyday use and its flat surface makes it easy to clean but please follow the following precautions.

- **Immediately switch off the appliance from the mains if a crack is detected on the ceramic glass surface and refer to the Guarantee section.**
- **Keep children away from hot surfaces.**
- In order to avoid hob soilage, make sure the bottom of the utensils and the hob surface are clean and dry before use.
- Do not use the surface for food preparation eg cutting bread or slicing vegetables and fruit.

- Do not use the surface for storing or any other non-cooking purpose.
- The scratching or dropping of sharp cornered pots onto the surface may cause damage.
- Do not place any material on the surface, such as plastic, aluminium, etc.
- Any such material that may have melted onto the surface should immediately be removed with a hob scraper.
- Never use a dishcloth or sponge to clean the ceramic hob as these may leave a layer of soiled detergent on the hob which will burn and discolour the next time the hob is used.
- Avoid heating up empty enamel pots.

# saucepan types

## Pan choice

In choosing pans, look for pan handles that can be held easily and will stay cool. Avoid pans that are unstable and easily tipped. Pans that are too heavy to move easily when filled can also be a hazard. Only use flat bottomed pots or pans.

## Pan size

For maximum efficiency and safety, use the recommended pan sizes for each burner.

- Use pans which have sufficient capacity for the amount of food being cooked so they don't boil over and cause unnecessary cleaning.
- Do not place lids on the burners. Always position pans centrally over the burners. When transferring pans from one burner to another always lift the pans do not slide them.
- Do not use aluminum-bottomed pots. (This results in the deterioration of the ceramic glass surface).
- Use steel or heat-resistant glass pots. Do not use pots made from materials such as "boron glass", or "Pyrex", which are generally oven-type containers.

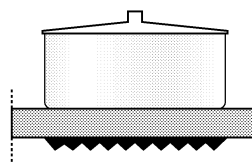

- Optimum efficiency is achieved by using pans that match the diameters of the elements

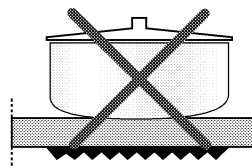

- If the pan is too small energy is wasted.

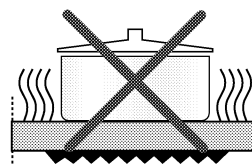

- Do not use pots that have concave or convex bottoms.

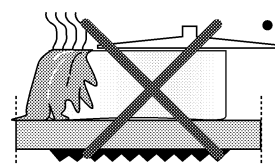

- Splashes may damage the ceramic surface and can cause fire.

# deep fat frying



- Never fill the pan more than the one-third full of fat or oil.
- Never leave unattended during heating or cooking.
- Do not fry too much food at the same time especially frozen food. This only lowers the temperature of the oil or fat too much resulting in greasy food.
- Always dry food thoroughly before frying and lower it slowly into the hot oil or fat. Frozen foods in particular will cause frothing and spitting if added too quickly.
- Never heat fat or fry with a lid on the pan.
- Keep the outside of the pan clean and free from streaks of oil or fat.

## In the event of a chip pan or other pan fire

- 1 Turn off the cooker.
- 2 Smother flames with a fire blanket or damp cloth.

Burns and injuries are caused almost invariably by picking up the burning pan and rushing outside with it.



**Do not use water on the fire.**  
**Leave the pan to cool for at least 30 minutes.**

## Turn OFF at the mains before cleaning.

- Before switching on again ensure that all controls are in the OFF position.
- **Make sure the hob is sufficiently cool before you start cleaning.**
- Never mix different cleaning products as different active ingredients may react with unforeseen results.

## Exterior

Use a damp cloth to clean the outside. Never use any sharp instruments, abrasive household cleaner, or detergents for cleaning. For hard stains use suitable washing liquid.

## Ceramic hob

Clean daily to avoid soilage being burnt on.

- 1 Be sure to use a cleaning agent that does not scratch the ceramic glass surface. We recommend Hob Brite Ceramic Hob Cleaner which is available from your local supermarket. Follow the manufacturer's instructions.
  - 2 Always rinse off fully with a clean cloth wrung out in clean water (as residue could damage the ceramic glass surface next time the hob is used).
  - 3 Wipe the surface dry with a soft cloth.
- **Do not use steel wool, abrasive powders, detergents or bleach-based cleaning agents as these will damage the surface.**
  - You can use a ceramic hob scraper (available through Hob Brite and good local stores) to remove spilled food remains and stubborn marks from the surface.
  - **Sugar-based food such as custard and syrup should immediately be scraped off without waiting for the surface to cool down. Otherwise the hob may be permanently damaged.**
  - Cleaning material that is suitable for ceramic hobs may damage other parts of your cooker, so take care with surrounding parts.

## Over time...

- Slight discolouration of liners and other surfaces may occur in time. This does not affect the functioning of the appliance.
- Discolourations and marks that occur on the ceramic hob are normal and not a fault.



## Caution hob Scrapers

Please keep children away from the hob scraper store securely.

## Suitable cleaning and care agents with a protective effect are, for example:

The application of materials with a protective effect is recommended. The film that is produced protects the cooktop to a great extent from stubborn dirt stains and décor damages.

Crusts from overcooked milk and non-sugar-containing foods can be removed in a warm as well as cool state. **Recommended for this is a razor blade scraper** which can be purchased at a speciality store. Hold the scraper at a low angle in order to avoid scratches. In no case should crusts be scratched off with serrated edge knives, steel wool or the like.

Remove calcium stains (yellow staining) with small amounts of decalcifying agents such as Durgol, vinegar or lemon juice. Apply agent with a sponge and, in the event of heavier soiling, let it work in for a longer period of time. Afterwards, wash off the hob with water.

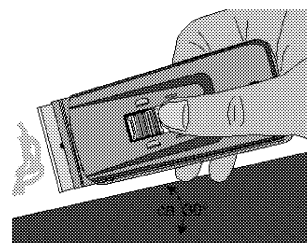
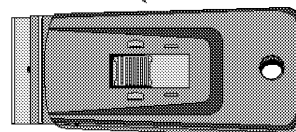
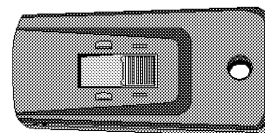

# trouble shooting

---



## **If the hob does not work**

If the appliance does not operate check whether:

- The power is on.
- The fuse has blown/circuit breaker has tripped/main distribution switch has been turned off.

If the appliance is still not operating after the above checks, please refer to the section on how to obtain service.

**Please ensure that the above checks have been made as a charge will be made if no fault is found.**

## **Performance characteristics when in use**

- It is normal for the metal parts to produce noise when in use, this is due to expansion and contraction.
- If, whilst cooking, steam produced comes in to contact with cool surface's on the outside of the appliance, it will condense and produce water droplets. This is quite normal and is not a fault.

# future transportation

---

## **Recycling**

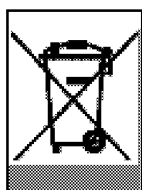

This product bears the selective sorting symbol for waste electrical and electronic equipment (WEEE). This means that this product must be handled pursuant to European Directive 2002/96/EC in order to

be recycled or dismantled to minimize its impact on the environment.

For further information, please contact your local or regional authorities.

Electronic products not included in the selective sorting process are potentially dangerous for the environment and human health due to the presence of hazardous substances.

Keep the original carton and other packaging material in a safe place. Transport the hob in its original carton. Follow the instructions that are printed on the carton.

## **If you do not have the original carton**

Secure the caps and Pan supports by adhesivetape.

Pack the oven in bubble wrap or thick cardboard and tape it securely in order to prevent damage during transportation.

The hob must be transported upright. Do not place other items on the top of the cooker.



Your Beko product is guaranteed against the cost of breakdown repairs for twelve months from the date of the original purchase.

## What is covered?

- All repairs necessary as a result of faulty materials, defective components or manufacturing defect.
- The cost of all functional replacement parts.
- The labour costs of a Beko approved repairer to carry out the repair.

## What is not covered?

- Transit or delivery damage
- Accidental damage
- Misuse, or abuse.
- Cabinet or appearance parts, including knobs and flaps
- Accessory items, including ice trays, scrapers, cutlery baskets,
- Repairs required as a result of unauthorised repairs or inexperienced installation that fails to meet the requirements contained in the user instruction book.

Repairs to products used on commercial or non-residential

household premises.

## Important notes.

- The product is guaranteed for domestic household use only.
- The guarantee will be void if the product is installed or used in commercial or non-residential household premises.
- The product must be correctly installed, located and operated in accordance with the instructions contained in the User Instructions Booklet provided.
- Professional Installation by a qualified plumber/electrical appliance installer is recommended for all Washing & Dishwashing Machines and Electric Cookers
- Gas Cookers must only be installed by a Gas Safe (or BORD GAIS) registered Gas Installer.
- The guarantee is given only within the boundaries of the United Kingdom.
- The guarantee is not transferable if the product is resold.
- Beko plc disclaims any liability for incidental or consequential damages.
- The guarantee does not in anyway diminish your statutory or legal rights.

## HOW TO OBTAIN SERVICE UNDER THE MANUFACTURERS GUARANTEE

Please keep your purchase receipt or other proof of purchase in a safe place; you will need to have it should the product require attention in the guarantee period

You should also complete the details below; it will help us assist you quicker when requesting service. (The model number is printed on the Instruction Booklet)

Model Number: \_\_\_\_\_

Purchased From: \_\_\_\_\_

Date of purchase: \_\_\_\_\_

For service under guarantee simply telephone the appropriate number below

### LOCATION

UK Mainland & Northern Ireland

Fridges & Freezers

Electric Cookers

Gas & Dual Fuel Cookers

Washing Machines & Dishwashers

Republic of Ireland

All Refrigeration, Cooking, Washing & Dishwashing Machines

### TELEPHONE

0845 600 4903

0845 600 4902

0845 600 4905

0845 600 4906

01 862 3411

Before requesting service please check the trouble-shooting guide in the Operating Instructions as a charge may be levied where no fault is found even though your product may still be under guarantee.

Service once the manufacturers guarantee has expired.

If you have purchased an extended guarantee please refer to the instructions contained within the extended guarantee agreement document. Otherwise please call the above numbers where service can be obtained at a charge.

Should you experience any difficulty in obtaining service please call the

**Beko Customer Help-Line on 0845 600 4911**

**Beko House, Caxton Way, Watford, Herts, WD18 8UF, Tel: 0845 600 4911**





