

# Refrigerator

User manual

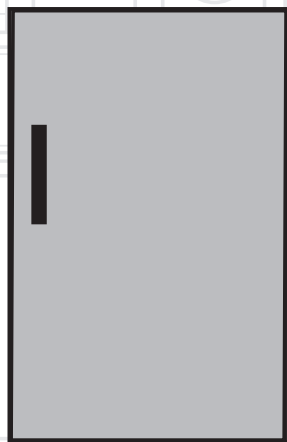

UL 584 APW

UL 584 APS

ULJS1584W

EN

**beko**

## **Please read this manual first!**

Dear Customer,

We hope that your product, which has been produced in a 1st-class manufacturing facility and checked under the most meticulous quality control procedures, will provide you with years of good service.

For this, we recommend you to carefully read the entire manual of your product before using it and keep it at hand for future reference.



## **This manual**

- Will help you use your appliance quickly and safely.
- Read the manual before installing and operating your product.
- Follow the instructions, especially those for safety.
- Keep the manual in an easily accessible place as you may need it later.
- Besides, read also the other documents provided with your product.

Please note that this manual may be valid for other models as well.

## **Symbols and their descriptions**

This instruction manual contains the following symbols:

-  Important information or useful usage tips.
-  Warning against dangerous conditions for life and property.
-  Warning against electric voltage.

---

<b>1 Your refrigerator</b>	<b>3</b>	<b>4 Before operating</b>	<b>12</b>
<b>2 Warnings</b>	<b>4</b>	Final Check .....	12
Electrical requirements.....	5	<b>5 Using your refrigerator</b>	<b>13</b>
Warning! This appliance must be earthed.....	5	Temperature Control And Adjustment .....	14
Energy saving tips.....	6	Defrosting .....	15
Compliance with WEEE Directive and Disposing of the Waste Product: .....	6	Changing the illumination lamp .....	15
Compliance with rohs directive: .....	6	<b>6 Maintenance and cleaning</b>	<b>16</b>
Package information.....	7	<b>7 Do's and Don'ts</b>	<b>17</b>
<b>3 Installation</b>	<b>8</b>	<b>8 Guarantee Details</b>	<b>18</b>
Transportation Instructions.....	8	<b>9 How To Obtain Service</b>	<b>19</b>
Installation Instructions .....	8		

# 1 Your refrigerator

Congratulations on your choice of a **Beko** quality Appliance which has been designed to give you service for many years.

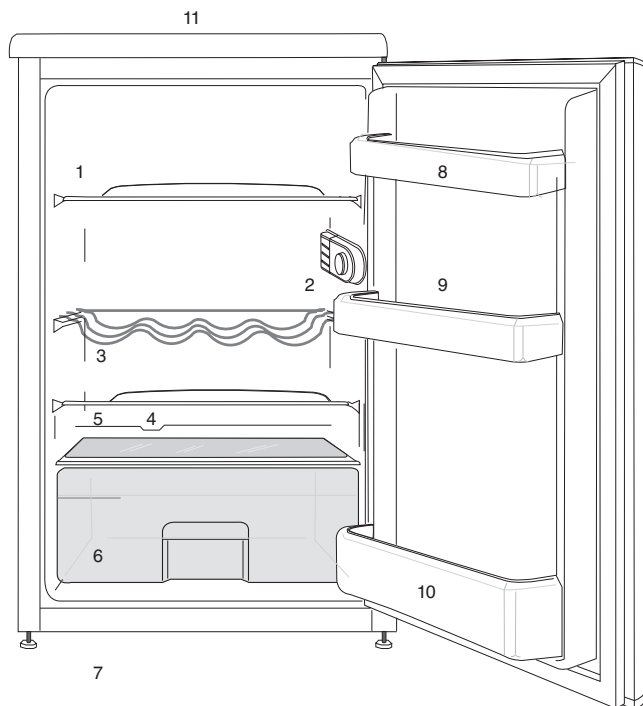

- |                                     |                          |
|-------------------------------------|--------------------------|
| 1. Movable shelves                  | 7. Adjustable front feet |
| 2. Interior light & Thermostat knob | 8. Door shelves          |
| 3. Wine rack                        | 9. Egg tray              |
| 4. Defrost water collection channel | 10. Bottle shelf         |
| - Drain tube                        | 11. Top trim             |
| 5. Crisper cover                    |                          |
| 6. Crisper                          |                          |

**ⓘ** Figures that take place in this instruction manual are schematic and may not correspond exactly with your product. If the subject parts are not included in the product you have purchased, then it is valid for other models.

## 2 Warnings

---

- Do not connect your appliance to the electricity supply until all packing and transit protectors have been removed.
- If transported horizontally leave to stand upright for at least 4 hours before switching on to allow compressor oil to settle
- If you are discarding an old refrigerator with a lock or latch fitted to the door, disable the lock/latch, ensure that it is left in a safe condition to prevent the entrapment of young children.
- This fridge/freezer must only be used for its intended purpose i.e the storing and freezing of edible foodstuff.
- Do not dispose of the appliance on a fire. At **Beko**, the care and protection of our environment is an ongoing commitment. This appliance which is among the latest range introduced is particularly environment friendly. Your appliance contains non CFC / HFC natural substances in the cooling system (Called R600a) and in the insulation (Called cyclopentane) which are potentially flammable if exposed to fire. Therefore, take care not to damage, the cooling circuit / pipes of the appliance in transportation and in use. In case of damage do not expose the appliance to fire or potential ignition source and immediately ventilate the room where the appliance is situated.
- We suggest you contact your local authority for disposal information and facilities available.
- To obtain the best possible performance and trouble free operation from your appliance it is very important to carefully read these instructions.
- On delivery, check to make sure that the product is not damaged and that all the parts and accessories are in perfect condition.
- Ensure that the plug remains readily accessible. Do not use multiple adapter or extension cable.
- Failure to observe these instructions may invalidate your right to free service during the guarantee period.
- Keep ventilation openings, in the appliance enclosure or in the built-in structure, clear of obstruction.
- Do not damage the refrigerant circuit.
- Do not use electrical appliances inside the food storage compartments of the appliance, unless they are of the type recommended by the manufacturer.

- We suggest you keep these instructions in a safe place for easy reference.
- This appliance can be used by children aged from 8 years and above and persons with reduced physical, sensory or mental capabilities or lack of experience and knowledge if they have been given supervision or instruction concerning use of the appliance in a safe way and understand the hazards involved. Children shall not play with the appliance. Cleaning and user maintenance shall not be made by children without supervision.
- Children should be supervised to ensure that they do not play with the appliance.

## Electrical requirements

Before you insert the plug into the wall socket make sure that the voltage and the frequency shown on the rating plate inside the appliance corresponds to your electricity supply.

Rating label is on the left hand side of fridge inner liner.

We recommend that this appliance be connected to the mains supply via a suitable switched and fused socket. The appliance must be positioned so that the plug is accessible.

### **WARNING:**

When positioning the appliance ensure the supply cord is not trapped or damaged.

Should the mains lead of the appliance become damaged or

should it need replacing at any time, it must be replaced by a special purpose made mains lead which can only be obtained from a **Beko** authorised service agent.

### **Warning! This appliance must be earthed**

If the fitted moulded plug is not suitable for your socket, then the plug should be cut off and an appropriate plug fitted. Destroy the old plug which is cut off as a plug with bared cord could cause a shock hazard if inserted into a socket elsewhere in the house.

The moulded plug on this appliance incorporates a 13 A fuse. Should the fuse need to be replaced an ASTABEAB approved BS 1362 fuse of the same rating must be used. Do not forget to refit the fuse cover. In the event of losing the fuse cover the plug must not be used until a replacement fuse cover has been fitted.

Colour of the replacement fuse cover must be the same colour as that visible on the pin face of the plug. Fuse covers are available from any good electrical store.

### **Important! Fitting A Different Plug**

1. As the colours of the wires in the mains lead of this appliance may not correspond with the coloured markings identifying the terminals in your plug proceed as follows: (See diagram).

2. Connect the green-yellow or green (Earth) wire to the terminal in the plug marked 'E' or with the symbol  or coloured green and yellow or green.
3. Connect the blue (Neutral) wire to the terminal in the plug marked 'N' or coloured black.
4. Connect the brown (Live) wire to the terminal in the plug marked 'L' or coloured red.
5. With alternative plugs a 13 A fuse must be fitted either in the plug or adaptor or in the main fuse box. If in doubt contact a qualified electrician.

### Energy saving tips

1. Ensure your appliance is installed in a well ventilated area.
2. Ensure the time between buying chilled/frozen food and placing them in your appliance is kept at minimum, particularly in summer. We recommend you use a cool bag or a special carrier bag to carry perishable food.
3. Do not leave the door (s) of your appliance open longer than necessary and ensure they are closed properly after each opening.
4. Defrost frozen food in the fridge compartment, so that frozen food acts as an ice pack to assist cooling in the fridge.
5. Energy consumption of this appliance is measured while

freezer compartment is loaded without use of top shelf lid and the drawers except the bottom drawer. It is advised that freezer compartment is loaded without use of drawers except the bottom drawer in order to achieve maximum loading capacity.

### Compliance with WEEE Directive and Disposing of the Waste Product:

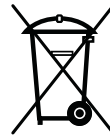

This product complies with EU WEEE Directive (2012/19/EU). This product bears a classification symbol for waste electrical and electronic equipment (WEEE). This product has been manufactured with high quality parts and materials which can be reused and are suitable for recycling. Do not dispose of the waste product with normal domestic and other wastes at the end of its service life. Take it to the collection center for the recycling of electrical and electronic equipment. Please consult your local authorities to learn about these collection centers.

### Compliance with rohs directive:

The product you have purchased complies with EU RoHS Directive (2011/65/EU). It does not contain harmful and prohibited materials specified in the Directive.

## **Package information**

Packaging materials of the product are manufactured from recyclable materials in accordance with our National Environment Regulations. Do not dispose of the packaging materials together with the domestic or other wastes. Take them to the packaging material collection points designated by the local authorities.



## 3 Installation

### Transportation Instructions

1. The appliance should be transported only in a vertical upright position. The packing as supplied must be intact during transportation.
2. If during the course of transport the appliance has to be transported horizontally, it must only be laid on its right hand side when standing in the front of the appliance. After bringing it to upright position, it must not be operated for at least 4 hours to allow the system to settle.
3. Failure to comply with the above instructions could result in damage occurring to the appliance. The manufacturer will not be held responsible if these instructions are disregarded.
4. The appliance must be protected against rain, moisture and other atmospheric influences.
5. Empty any water in the drain tray before moving see section "Defrosting" and "Cleaning & Care" for further information

#### **Important :**

Make sure the plastic evaporating pan at the back of the product collects water properly.

#### **Important :**

Care must be taken while cleaning / carrying the appliance to avoid touching the bottom of the condenser metal wires at the back of the appliance as you might injure your fingers and hands.

#### **Important :**

This appliance is not designed for stacking with any other appliance. When positioning your appliance, take care not to damage your flooring, pipes, wall coverings etc. Do not move the appliance by pulling by the door or handle. Do not attempt to sit or stand on top of your appliance as it is not designed for such use. You could injure yourself or damage the appliance.

#### **Important :**

Make sure that mains cable is not caught under the appliance during and after carrying / moving the appliance, to avoid the mains cable becoming cut or damaged. "Do not allow children to play with the appliance or tamper with the controls.

BEKO declines to accept any liability should the instructions not be followed.

### Installation Instructions

1. If possible avoid placing the appliance near cookers, radiators or in direct sunlight as this will cause the compressor to run for long periods. If installed next to a source of heat or refrigerator, maintain the following minimum side clearances:

From Cookers 2" (50 mm)

From Radiators 12" (300 mm)

From Refrigerators or Larder Fridge 1" (25 mm)

2. No gap is required at sides and top. See item 3 below to ensure a gap is obtained at the rear of the appliance. If a gap is available on side and top, retain it if possible as it would improve the air circulation around the appliance.

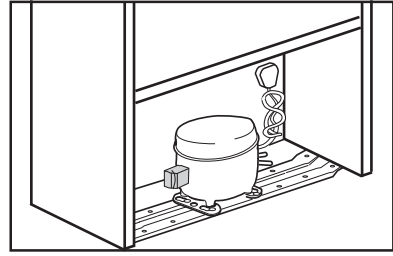
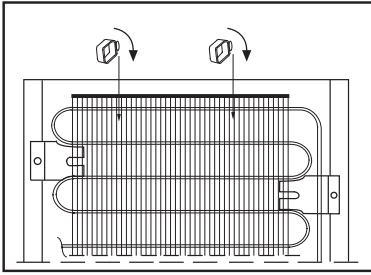

3. Fit the two plastic wall spacer supplied with the appliance on to the condenser at the back of the refrigerator by rotating 1/4 turn (see diagram).
4. The appliance should be located on a smooth surface. The two front feet can be adjusted as required. To ensure that your appliance is standing upright adjust the two front feet, by turning clockwise or anti-clockwise, until the product is in firm contact with the floor. Correct adjustment of feet avoids excessive vibration and noise.
5. Refer to "Cleaning and Care" section to prepare your appliance for use.
6. This appliance has been designed to operate in ambient temperatures between +10 and +32 degrees C (50 and 90 degrees F). Therefore if the appliance is installed in an unheated / cold room (E.g.: Conservatory /annex / shed / garage etc.) then the appliance may not operate and as a result the storage time of food may be reduced.
7. A special receptacle is supplied to store the mains plug during transit. The receptacle is fixed at the back of the cabinet, on the right hand side of the compressor. (See diagram) Gently remove the plug from the receptacle.
8. Never pull the mains cord, you may damage the appliance. In the case of transportation, ensure you locate the plug in the receptacle provided to avoid transit damage. The space in the room where the appliance is installed must not be smaller than 10 cubic metres.

**WARNING:**

Do not locate extension sockets or charging transformers/power supplies or Lithium-Iron battery operated products adjacent to the compressor as they could overheat.

## Repositioning The Door

Follow the step by step instructions and the diagram below.  
Numbers in brackets refer to diagrams.

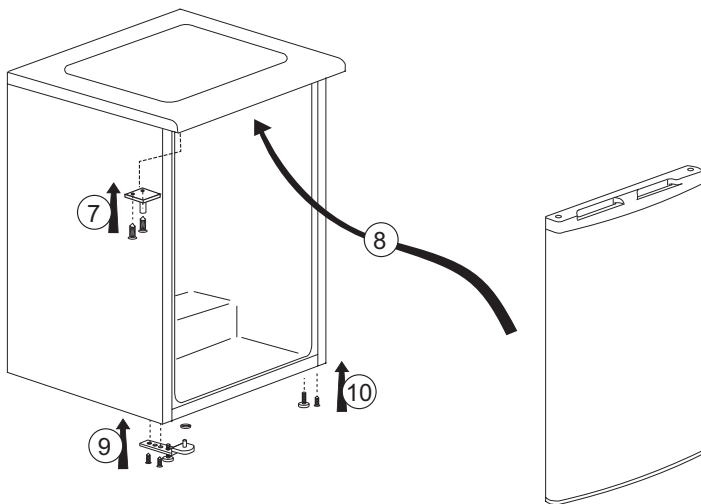
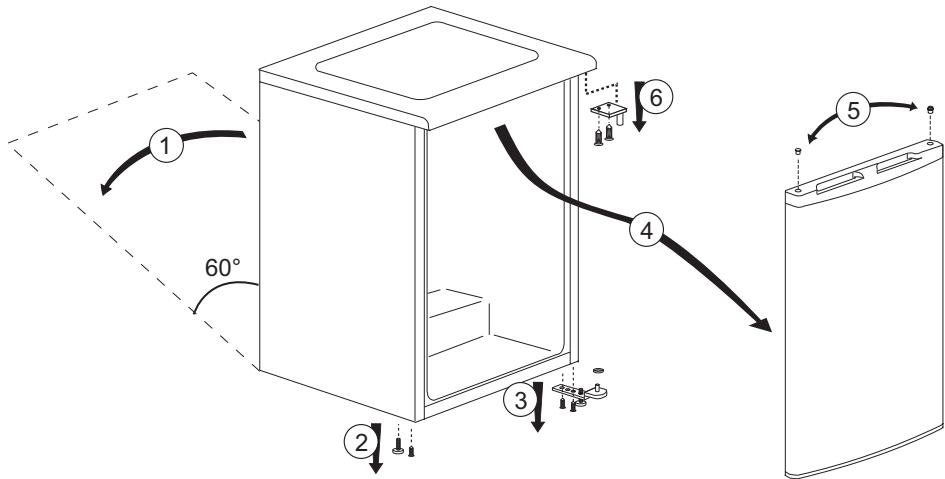

**1.** Switch off at the socket outlet and pull out the mains plug.

**2.** Remove all food, loose items and fittings from inside the appliance and door shelves.

**3.** Carefully tilt the appliance on its back side. (1) (You may need somebody to help you.) Take care not to damage the appliance by laying on some protective material (e.g. its original packaging). Make sure that you tilt the appliance on its back side, otherwise compressor oil may block the pipes and you may damage the appliance.

**4.** Unscrew and remove the LHS front feet and bolt (2).

**5.** Unscrew the bolts and remove the bottom hinge while holding the door (3).

**6.** Remove the door carefully from the top hinge by sliding down wards (4).

**7.** Reposition top hinge bushing and blanking plug on the opposite side and stand the door safely (5). You may find it easier to remove the bushing and the plug with the tip of a small screwdriver. Take care not to mark the door.

**8.** Reposition the top hinge on the opposite side (6 and 7).

**9.** To refit the door, locate the top hinge in the door, attach to the cabinet and hold the door (8).

**10.** Fit the bottom hinge (9). If necessary adjust and then tighten the bolts. Ensure, that the door opens and closes easily and that there are no gaps allowing air into the cabinet. If there are gaps between the door seal and the cabinet, adjust the door seal by gently pulling away from the door using fingers.

**11.** Fit the other front feet .

**12.** Fit the plugs on the holes on inner liner .

**13.** Carefully stand your appliance. (You may need somebody to help you.)

**14.** Adjust the front feet (See Installation Instructions)

**15.** Put back all, loose items and fittings.

**16.** Wait for at least 4 hours to allow the system to settle before switching on. Spare plastic parts supplied with the appliance are for your future use during door repositioning.

## 4 Before operating

---

### Final Check

Before you start using the fridge/freezer check that:

1. The feet have been adjusted for perfect levelling.
2. The interior is dry and air can circulate freely.
3. Clean the interior as recommended under "Cleaning And Care."
4. Insert the plug into the wall socket and switch on the electricity supply. When the door is open the interior light will come on.
5. You will hear a noise as the compressor starts up. The liquid and gases sealed within the refrigeration system may also give rise to noise, whether the compressor is running or not which is quite normal.
6. Slight undulation of the top of the cabinet is quite normal due to the manufacturing process used, so do not worry, it is not a defect.
7. We recommend that you set the thermostat knob at 3 (three) and monitor the temperature to ensure the appliance maintains desired storage temperatures (See section Temperature Control and Adjustment).
8. Do not load the appliance immediately it is switched on. Wait until the correct storage temperature has been reached. We recommend that you check the temperature with an accurate thermometer (see; Temperature Control and Adjustment).
9. Important Note :Ice formation at the back is normal, do not worry. (See Defrosting)

## 5 Using your refrigerator

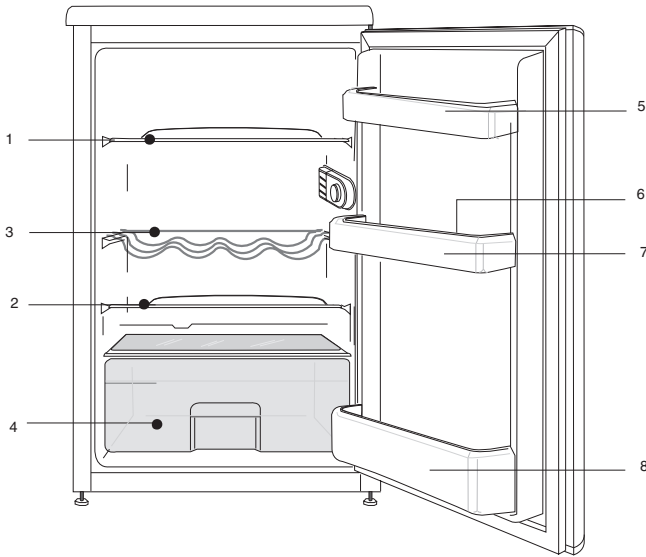

### Arrangement Examples (See diagram).

1. Baked, chilled cooked food, dairy products.
2. Meat, sausages, cold cuts, cans.
3. Wine rack
4. Fruit, vegetables, salads.
5. Tubes, small bottles and cans.
6. Egg tray.
7. Butter, cheese, dairy products.
8. Beverages, large bottles.

The following guidelines and recommendations are suggested to obtain the best results and storage hygiene.

1. Appliance is for the short term storage of fresh food and drinks.

2. Cooked dishes must be stored in airtight covered containers and are best placed on either of the removable shelves.
3. Fresh wrapped produce can be placed on the shelf. Fresh fruit and vegetables should be cleaned and stored in the crisper bins.
4. Bottles can be placed in the door section.
5. To store raw meat, wrap in polythene bags and place on the lowest shelf. Do not allow to come into contact with cooked food to avoid contamination. For safety, only store raw meat for two to three days.
6. Shelves incorporate rear stops and tilting for storing bottles. Lift shelf to clear grooves when adjusting.

7. To tilt a shelf place the back of the shelf one level below the front of the shelf. To remove a tilted shelf, first release the back off the grooves and then pull it.

8. Keep the food packed, wrapped or covered. Allow hot food and beverages to cool before placing them in the fridge. Do not store explosive substances in the refrigerator. High proof alcohol must be stored upright in sealed containers. Left over canned food should not be stored in the can.

**9. Side handle to be fitted by the user (Supplied in the appliance)**

10. Some fruit and vegetables suffer damage if kept at temperatures near 0 degrees centigrade. Therefore wrap pineapples, melon, cucumbers, tomatoes and similar produce in polythene bags.

11. Shelves, racks, crisper bins, dairy compartments, drawers, bottle grippers are all removable.

12. Always wrap food using a suitable packaging material before storing in your appliance to avoid contact with the appliance surface and food remains for hygiene reasons.

## Temperature Control And Adjustment

Operating temperatures are controlled by the thermostat (seediagram). Settings may be made from 1 to 5, the coldest position.

When the appliance is switched on for the first time, the thermostat should be adjusted so that after 24 hours, the average fridge temperature is no higher than +5°C (+41°F).

We recommend you set the thermostat halfway between the 1 and 5 setting and monitor to obtain the desired temperature i. e. towards 5 you will obtain a colder fridge temperature and vice versa. Some sections of the fridge

may be cooler or warmer ( such as the salad crisper and the top part of the cabinet ) which is quite normal. Over ambient temperatures of 25°C (77°F) especially in summer turn the thermostat knob towards 5. Under ambient temperatures of 25°C (77°F) turn the thermostat knob to a half way position.

Frequent door opening cause higher internal temperatures, so close the door as soon as possible after use. In case of a temporary ice build up in the fridge compartment reduce the thermostat setting to 1, monitoring at the same time that the fridge temperature is maximum +5 degrees C (41 degrees F). Once the ice build up disappears and the appliance starts auto defrosting again as normal, then you may increase the thermostat setting, if required.



## Defrosting

The larder fridge defrosts automatically. The defrosting water runs to the drain tube via a collection channel and is evaporated in a special container (1) at the back of the appliance (see diagram).

During defrosting water droplets may format the back of the larder fridge where concealed evaporator is located. Some droplets may remain on the liner and refreeze when defrosting is completed.

Do not use pointed or sharp edged objects such as knives, forks to remove the droplets which have refrozen. If at any time the defrost water does not drain from the collection channel, check to ensure that no food particles have blocked the drain tube.

The drain tube can be cleared by pushing the special plastic plunger provided down the drain tube.

## Changing the illumination lamp

To change the Bulb/LED used for illumination of your refrigerator, call your AuthorisedService.

The lamp(s) used in this appliance is not suitable for household room illumination. The intended purpose of this lamp is to assist the user to place foodstuffs in the refrigerator/freezer in a safe and comfortable way. The lamps used in this appliance have to withstand extreme physical conditions such as temperatures below -20 °C.

(only chest and upright freezer)

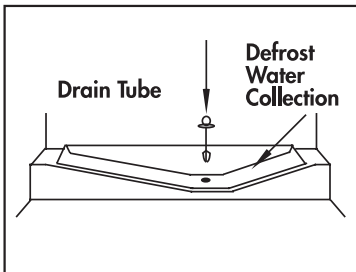



## 6 Maintenance and cleaning

---

- We recommend that you switch off the appliance at the socket outlet and pull out the mains plug before cleaning.
  - Never use any sharp abrasive instrument, soap, household cleaner, detergent and wax polish for cleaning.
  - Use luke warm water to clean the cabinet of the appliance and wipe it dry.
  - Use a damp cloth wrung out in a solution of one teaspoon of bicarbonate of soda to one pint of water to clean the interior and wipe it dry.
  - If the appliance is not going to be used for a long period of time switch it off, remove all food, clean it and leave the door ajar.
  - Any dust that gathers on the condenser, which is located at the back of the should be removed once a year with a vacuum cleaner.
  - Check door seals regularly to ensure they are clean and free from food particles..
  - Never :
  - Clean the worktop with unsuitable material; eg petroleum based products. Subject it to hot temperatures in any way. Scour, rub etc., with abrasive material.
- ⚠ Never use cleaning agents or water that contain chlorine to clean the outer surfaces and chromium coated parts of the product. Chlorine causes corrosion on such metal surfaces.

## 7 Do's and Don'ts

---

Do- Clean your appliance regularly (See "Cleaning and Care")

Do- Keep raw meat and poultry below cooked food and dairy products.

Do-Keep food for as short a time as possible and adhere to 'Best Before' and "Use By" dates.

Do- Take off any unusable leaves on vegetables and wipe off any soil.

Do- Leave lettuce, cabbage, parsley and cauliflower on the stem.

Do- Wrap cheese firstly in greaseproof paper and then in a polythene bag excluding as much air as possible. For best results take out of the fridge compartment an hour before eating.

Do- Wrap raw meat and poultry loosely in polythene or aluminium foil. This prevents drying.

Do- Wrap fish and offal in polythene bags.

Do- Wrap food which have a strong odour or can dry out in polythene bags, aluminium foil or place in an airtight container.

Do- Wrap bread well to keep it fresh.

Do- Chill white wines, beer, lager and mineral water before serving.

Don't- Store bananas in your fridge.

Don't- Store melon in your fridge. It can be chilled for short periods as long as it is wrapped to avoid it flavouring other food.

Don't- Leave the door open for long periods as this will make the larder refrigerator more costly to run.

Don't- Don't- Store poisonous or any dangerous substances in the larder refrigerator. Your larder refrigerator has been designed for the storage of edible foodstuffs only.

Don't- Consume food which has been stored for an excessive time in the larder refrigerator.

Don't- Consume food which has been stored for an excessive time in the larder refrigerator.

Don't- Store cooked and fresh food together in the same container. They should be packaged and stored separately.

Don't- Let defrosting food or food juices drip onto food in your larder refrigerator.

### **Problem Solving**

If the appliance does not operate when switched on, check whether:

- The plug is inserted properly in the socket and that the power supply is on. (To check the power supply to the socket, plug in another appliance)
- The fuse has blown/circuit breaker has tripped/main distribution switch has been turned off.
- The temperature control has been set correctly.
- New plug is wired correctly if you have changed the fitted moulded plug.

If the appliance is still not operating after the above checks, please refer to the section on "How To Obtain Service".

Please ensure that above checks have been made as a charge will be made if no fault is found.

## 8 Guarantee Details

---

### GUARANTEE DETAILS

Your new Beko product is guaranteed against the cost of breakdown repair for twelve months from the date of the original purchase.

#### What is covered?

- Repairs necessary as a result of faulty materials, defective components or manufacturing defect
- The cost of functional replacement parts, but excluding consumable items.
- The labour costs of a Beko approved repairer to carry out the repair.

#### What is not covered?

- Transit, delivery or accidental damage or misuse and abuse.
- Cabinet or appearance parts, including control knobs, flaps, handles or container lids.
- Accessories or consumable items including but not limited to, ice trays, scrapers, cutlery baskets, filters and light bulbs.
- Repairs required as a result of unauthorised repair or inexperienced installation that fails to meet the requirements contained in the user instruction book.
- Repairs to products used on commercial or non-residential household premises.
- Loss of frozen food in freezers or fridge/freezers. (Food loss insurance is often included within your household contents insurance policy, or may be available separately from your retailer).

#### Important notes.

- Your Beko product is designed and built for domestic household use only.
- The guarantee will be void if the product is installed or used in commercial or non-residential domestic household premises.
- The product must be correctly installed, located and operated in accordance with the instructions contained in the User Instructions Booklet provided.
- Professional installation by a qualified Electrical Domestic Appliance Installer is recommended for all Washing Machines, Dishwashers and Electric Cookers
- Gas Cookers must only be installed by a Gas Safe (or BORD GAIS) registered Gas Installer.
- The guarantee is given only within the boundaries of the United Kingdom and the Republic of Ireland.
- The guarantee is applicable only to new products and is not transferable if the product is resold.
- Beko disclaims any liability for incidental or consequential damages. The guarantee does not in any way diminish your statutory or legal rights.

## 9 How To Obtain Service

---

### HOW TO OBTAIN SERVICE

**Please keep your purchase receipt or other proof of purchase in a safe place; you will need to have it should the product require attention under guarantee.**

You should also complete the details below; it will help us assist you when requesting service. (The model number is printed on the Instruction Booklet and the serial number is printed on the Rating Label affixed to the appliance)

**Model No:** Obtaining service please contact Beko Customer Help-Line.

**Serial No:**

**Retailer:**

**Date of purchase:** Tel: 0845 6004911 or 0345 6004911

**For service under guarantee simply telephone the appropriate number below**

#### UK Mainland & Northern Ireland

Fridges & Freezers	0845 6004903	or	0345 6004903
Electric Cookers	0845 6004902	or	0345 6004902
Gas & Dual Fuel Cookers	0845 6004905	or	0345 6004905
Washing Machines & Dishwashers	0845 6004906	or	0345 6004906

#### Republic of Ireland

All Refrigeration 01 862 3411

All Cookers

Washing Machines & Dishwashers

**Before requesting service please check the trouble-shooting guide in the Operating Instructions as a charge may be levied where no fault is found even though your product may still be under guarantee.**

#### **Service once the manufacturers guarantee has expired.**

If you have purchased an extended guarantee please refer to the instructions contained within the extended guarantee agreement document. Otherwise please call the appropriate number above where service can be obtained at a charge.

Should you experience any difficulty in obtaining service please contact the Beko Customer Help-Line. Tel: 0845 6004911 e-mail: [service@beko.co.uk](mailto:service@beko.co.uk)



**BEKO plc**  
**Beko House**  
**1 Greenhill Crescent**  
**Watford**  
**Hertfordshire**  
**WD18 8QU**  
**Tel: 0845 6004911**  
**Fax: 0 845 6004922**  
**e-mail: [service@beko.co.uk](mailto:service@beko.co.uk)**  
**website: [www.beko.co.uk](http://www.beko.co.uk)**

57 12270000/AV